

VB0275

Introducing the industry's most advanced residential fresh air system, created to offer a universal platform specifically designed and improved to make contractors life easier and more profitable while delivering constant superior air quality.

- Thanks to the Virtuo Air Technology™, the airflow calibration and auto-balancing are achieved quickly and maintained throughout the life of the product
- Select the desired CFM (from 35 to 136 CFM) using the very first integrated LCD screen. The airflow is then set up automatically
- Integrated electronic airflow measurement device with real time LCD
- Integrated diagnostic tool
- Equipped with PMSM ECM motors for a very low power consumption
- Suspended installation (chains included)
- OR
- Wall-mount installation (universal brackets included)
 - installation with 2 brackets
 - installation with 4 brackets

CONTROLS



There are 3 optional main controls and 2 optional auxiliary controls available. Refer to Wall Control specification sheet for more information.

PRODUCT SPECIFICATIONS SUBJECT TO CHANGE WITHOUT NOTICE.

Fresh Air Systems - 130 CFM

ERV

Top ports: V150E75NT

Side ports: V150E75NS

35 to 136 CFM @ 0.2 in. w.g.

35 to 127 CFM @ 0.4 in. w.g.



PARTS/MOTOR/ERV CORE

UNIT DESCRIPTION

- SRE of 75% at 0°C (65 CFM) and 57% at -25°C (66 CFM)
- Ports size: 5 in.
- Recirculation defrost
- No recirculation mode
- Painted door, corrosion resistant galvanized body
- One-piece molded insulation shell, no air leakage (expanded polystyrene; UL 94 HF-1 certified)
- Virtuo constant airflow and auto-balancing device (patent pending)
- Motorized dampers (no additional backdraft dampers required)
- No drain required
- 6' power cord
- Unit electrical characteristics: 120 volts, 60 Hz, 2.5 A, 163 W
- Sound: 73.2 dBA at 127 CFM @ 0.4 in. w.g.
60.1 dBA at 64 CFM @ 0.2 in. w.g.

CORE

- Polypropylene crossflow core with polymeric membrane and aluminum covers, impact resistant, non washable
- Dimensions: 12" x 12" x 9" (30.5 cm x 30.5 cm x 23 cm)

FILTERS

- MERV 8 grade washable standard filter (included)
- Optional MERV13 grade filter part no. V24285

OPTIONS

- Complete line of registers and diffusers
- Compatible with the Tandem transition (part no. 14690) (for units producing up to 110 CFM only)

5" PORTS DIMENSIONS (TOP PORTS)

- 1 - Exhaust air from building
- 2 - Fresh air to building
- 3 - Exhaust air to outside
- 4 - Fresh air from outside

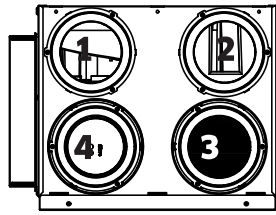

Total assembled weight: approx 37 lbs (16.8 kg) (core included)
Shipping weight: approx 44 lbs (20 kg)

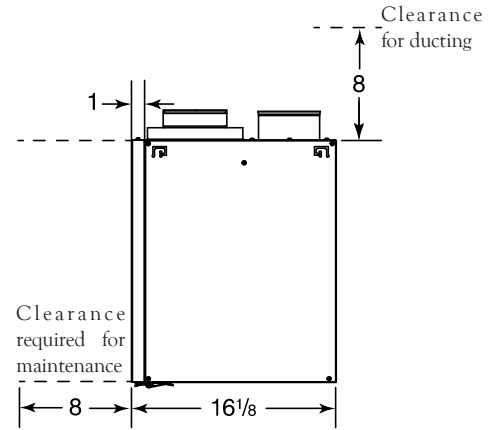
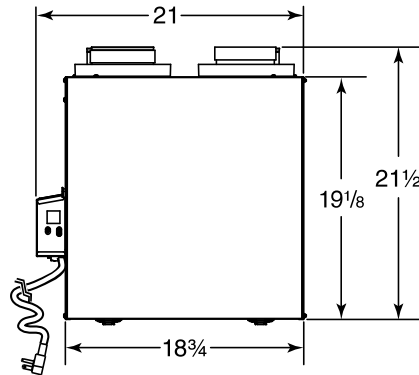
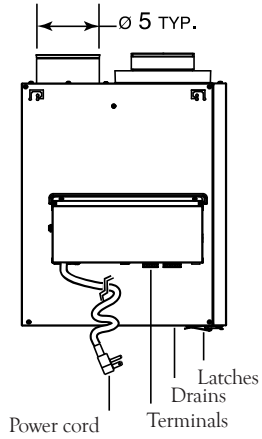

5" PORTS DIMENSIONS (SIDE PORTS)

- 1 - Exhaust air from building
- 2 - Fresh air to building
- 3 - Exhaust air to outside
- 4 - Fresh air from outside

Total assembled weight: approx 37 lbs (16.8 kg) (core included)
Shipping weight: approx 44 lbs (20 kg)

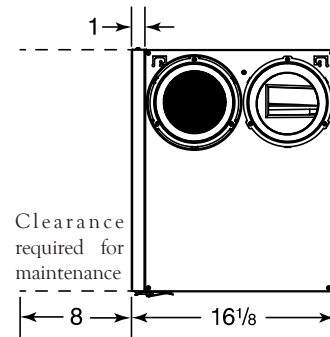
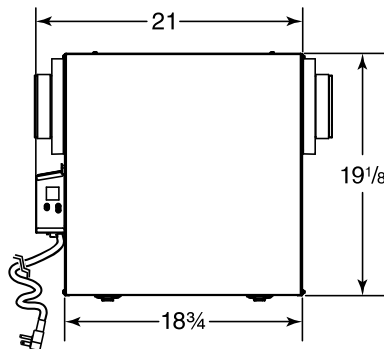
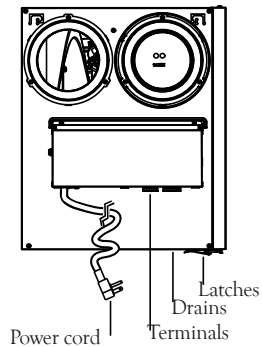
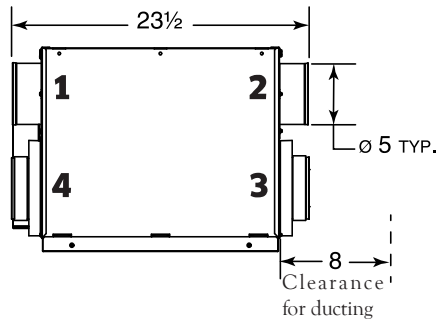

DEFROST SYSTEM

Homeshield™ Defrosting System

No negative pressure is created by air exhausted to the outdoors since the air is recirculated into the house, helping to prevent any backdraft.

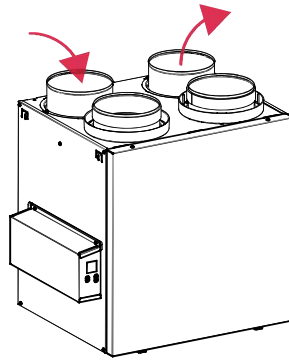

DISCRETION (Factory setting)	OUTDOOR TEMPERATURE*					
	-5°C TO -15°C 23°F TO 5°F		-15°C TO -27°C 5°F TO -17°F		-27°C AND LESS -17°F AND LESS	
CFM	AIR EXCHANGE IN MINUTES	DEFROST IN MINUTES	AIR EXCHANGE IN MINUTES	DEFROST IN MINUTES	AIR EXCHANGE IN MINUTES	DEFROST IN MINUTES
0 to 59	22	6	13	5	12	7
60 to 109	22	6	14	5	13	7
110 and more	13	6	9	5	9	7

*Outdoor temperature is read by a thermistor located inside the unit, next to fresh air from outdoor port.

NOTE: There is a 10-minute additional defrost every 5 defrost cycles.

PLUS	OUTDOOR TEMPERATURE*					
	-5°C TO -15°C 23°F TO 5°F		-15°C TO -27°C 5°F TO -17°F		-27°C AND LESS -17°F AND LESS	
CFM	AIR EXCHANGE IN MINUTES	DEFROST IN MINUTES	AIR EXCHANGE IN MINUTES	DEFROST IN MINUTES	AIR EXCHANGE IN MINUTES	DEFROST IN MINUTES
0 to 59	22	7	13	7	12	8
60 to 109	22	7	14	7	13	8
110 and more	13	7	9	7	9	8

*Outdoor temperature is read by a thermistor located inside the unit, next to fresh air from outdoor port.

NOTE: There is a 10-minute additional defrost every 5 defrost cycles.

FAN CURVES WITH VIRTUO

Thanks to Virtuo Air Technology™, no need to balance the unit manually. Both PMSM motors are controlled by an artificial intelligence performing 120 readings per minute then processing this information to maintain the requested airflow.

For typical installation, Virtuo will ensure a balanced ventilation at every selected speed regardless of the weather conditions, the type of connection, the variable speed furnace/AHU, the stack effect, the filter clogging and so on. This results in peace of mind for installers and users knowing that the unit will always remain balanced and that it will maintain its maximum heat/energy recovery efficiency.

STATIC PRESSURE (PA)	STATIC PRESSURE (IN. W.G.)	NET SUPPLY AIRFLOW (L/s)	NET SUPPLY AIRFLOW (CFM)	GROSS AIRFLOW SUPPLY (L/s)	GROSS AIRFLOW SUPPLY (CFM)	GROSS AIRFLOW EXHAUST (L/s)	GROSS AIRFLOW EXHAUST (CFM)
25	0.1	65	138	67	142	67	142
50	0.2	64	136	66	140	66	140
75	0.3	62	131	64	136	64	136
100	0.4	60	127	62	131	62	131
125	0.5	58	123	60	127	60	127
150	0.6	56	119	57	121	57	121
175	0.7	54	114	55	117	55	117
200	0.8	51	108	52	110	52	110
225	0.9	49	104	50	106	50	106
250	1.0	46	97	47	100	47	100

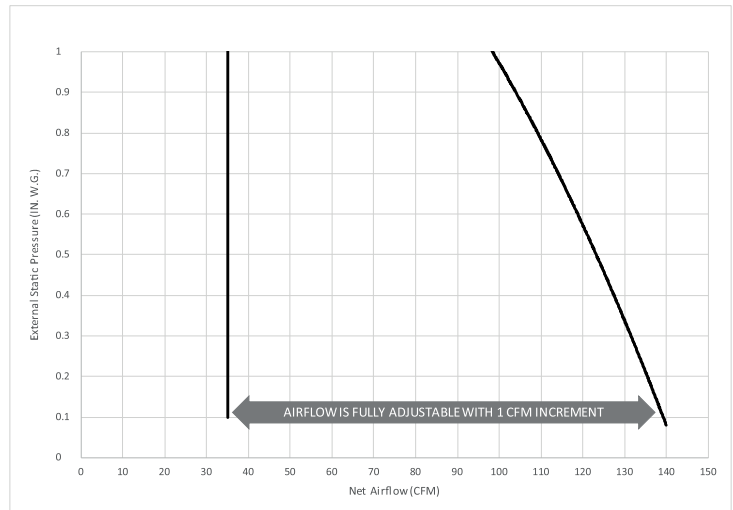

ENERGY PERFORMANCE

SUPPLY TEMPERATURE		NET AIRFLOW		POWER CONSUMED WATTS	SENSIBLE RECOVERY EFFICIENCY	ADJUSTED SENSIBLE RECOVERY EFFICIENCY	APPARENT SENSIBLE EFFECTIVENESS*	TOTAL RECOVERY EFFICIENCY	ADJUSTED TOTAL RECOVERY EFFICIENCY	LATENT PERFORMANCE COEFFICIENT
°C	°F	L/S	CFM							
HEATING										
0	32	31	65	35	75	79	80	-	-	67
0	32	59	125	110	69	75	76	-	-	59
-25	-13	31	66	70	57	60	74	-	-	58
35	95	31	65	41	-	-	73	67	69	69
35	95	59	125	120	-	-	63	56	60	60

* Data not certified by HVI.

REQUIREMENTS AND STANDARDS

- UL 1812 compliant (safety)
- Could be installed in compliance with CSA F326
- Performance tested as per CSA C439 Standard
- Complies with ROHS 2015/863 directive
- Compliant with Prop 65

Project:	Remarks
Location:	
Part no.:	
Qty.:	
Submitted by: _____ Date: _____	

