

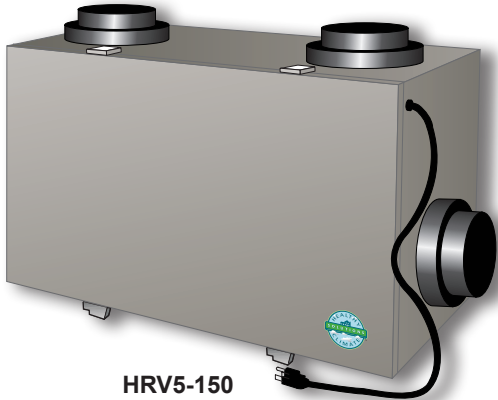

INDOOR AIR QUALITY
HRV / ERV
HEALTHY CLIMATE®
Heat / Energy Recovery Ventilator

Bulletin No. 210528
 May 2016
 Supersedes February 2015

PRODUCT SPECIFICATIONS



HRV5-150



ERV3-150, -200



HRV3-150-TPD/TPF, HRV5-200-TPD



HRV3-095

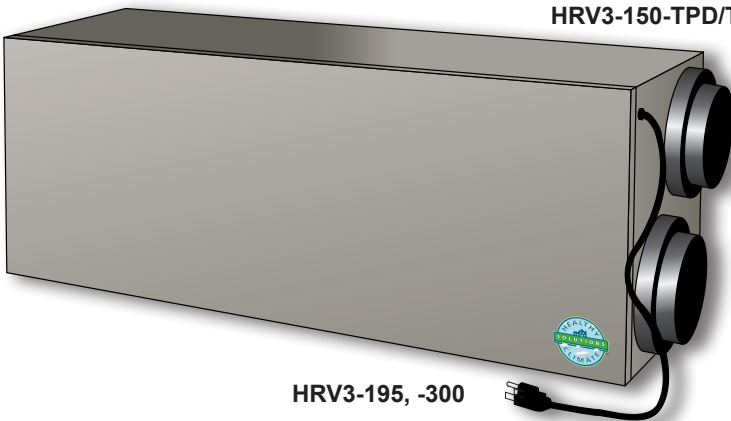

HRV3-195, -300

Certain models have earned the ENERGY STAR® mark by meeting strict energy efficiency guidelines set by Natural Resources Canada and the US EPA. These models meet ENERGY STAR requirements only when used in Canada.



MODEL NUMBER IDENTIFICATION

HRV 5 - 200 - TPD

Unit Type
 HRV = Heat Recovery Ventilator
 ERV = Energy Recovery Ventilator

Generation
 3 = 3rd Generation
 5 = 5th Generation

Defrost Type (Certain Models)
 TPD = Top Port Damper Defrost
 TPF = Top Port Fan Defrost

Number of Cores
 095 = Single Core
 150 = Single Core
 195 = Dual Core
 200 = Single Core
 300 = Dual Core

FEATURES

CONTENTS

Accessory Dimensions	15
Application Map	7
Blower Data	13
Dimensions	14
Electrical Data.....	10
Features.....	2
Model Number Identification	1
Optional Accessories	12
Specifications - ERV	11
Specifications - HRV	10
System Sizing.....	8
Typical System Applications	16

WARRANTY

HRV Aluminum Core - Limited lifetime warranty in residential applications, one-year in non-residential.

ERV Enthalpic Core - Limited ten year warranty in residential applications, one-year in non-residential.

All other covered components - Limited five year warranty in residential applications, one-year in non-residential.

Refer to Limited Warranty Certificate included with the equipment for more details.

APPROVALS

All units are CSA certified to UL 1812 and CSA 22.2.

Performance is certified by the Home Ventilating Institute (HVI).

Units conform to the Canadian Home Builders' Association R-2000 Standard and meet Heating, Refrigeration and Air Conditioning Institute of Canada (HRAI) standards.

All units conform to CAN/ULC-S110-M1986 for non combustible material and CAN/ULC-S102-M88 for flame spread rating and smoke developed classification.

Certain models have earned the ENERGY STAR® by meeting strict energy efficiency guidelines set by Natural Resources Canada and the US EPA. These models meet ENERGY STAR requirements only when used in Canada. See Specifications table for qualified models.

ISO 9001 Registered Manufacturing Quality System.

Units are completely wired and include filters.

INSTALLATION GUIDELINES

Lennox recommends that the HRV/ERV unit be installed in a conditioned space. If the unit is installed above a ceiling a separate, secondary drain pan should also be installed under the unit. If the unit is installed in an unconditioned area condensate lines must be protected against freezing temperatures.

APPLICATIONS

See System Sizing section on page 8 to determine the right model for the desired application. If use of HRV/ERV with a dehumidifier and HEPA/Carbon Filtration for optimal Indoor Air Quality (IAQ) is desired, see Lennox Service & Application Notes "HEPA Filtration with Outdoor Air and a Dehumidifier".

HRV

Heat Recovery Ventilators (HRV) provide fresh, clean outdoor air with an energy saving temperature recovery of up to 90%.

HRV's are recommended in regions where normal humidity levels occur. See Application Map on page 7.

Intake and exhaust air passes through a patented thermally conductive aluminum core where heat is transferred from exhaust air to incoming air.

NOTE - HRV3-150-TPD, HRV3-150-TFP and HRV5-200-TPD are top port models with four oval collars. TPD models have a top port damper defrost, TPF models have a top port fan defrost. See dimension drawings for additional information.

ERV

Energy Recovery Ventilators (ERV) provide fresh clean outdoor air while reducing humidity levels at the same time.

ERV's are recommended in regions where high outdoor humidity levels occur. Not recommended where outdoor temperatures fall below 25°F continuously for more than five days. See Application Map on page 7.

Intake and exhaust air passes through an enthalpic core where heat is transferred from exhaust air to incoming air and moisture is reduced.

HRV / ERV

Centrifugal blowers bring in fresh outdoor air while at the same time exhausting an equal amount of stale indoor air.

A duct system distributes the fresh air and collects the stale air for removal from the building.

System airflow must be balanced for maximum efficiency. Refer to Installation Instructions for system air flow balancing details.

FEATURES

CORE ASSEMBLY

HRV Patented Aluminum Core

Aluminum plates have excellent heat transfer characteristics, are nonflammable, corrosion resistant and durable.

Plates are mounted in plastic frame and are easily removable for cleaning.

Opposed dimples pressed into each plate ensure proper separation within each core.

Modular design ensures ease of service.

ERV Enthalpic Core

Enthalpic core has excellent latent and sensible heat transfer characteristics, are nonflammable, corrosion resistant and durable.

UL recognized component.

Plates are mounted in a frame and are easily removable for cleaning.

Modular design ensures ease of service.

BLOWER

Dual centrifugal type with single motor.

Rubber insulated mounts furnished on all models.

Blower motor housing design allows easy access for servicing.

Multi-speed direct drive PSC motor (up to 5 speed settings with optional control).

DEFROST (HRV ONLY)

The HRV has an electronically controlled defrost mechanism. The defrost cycle is activated when the outdoor temperature drops below 27°F. Three recirculating defrost modes are available. Defrost run times vary based on incoming fresh air temperature.

1. At 27°F HRV runs in defrost for 3 minutes and runs in ventilation for 25 minutes
2. At -4°F HRV runs in defrost for 4.5 minutes and runs in ventilation for 17 minutes
3. At -31°F HRV runs in defrost for 7 minutes and runs in ventilation for 15 minutes

No remote device can override this defrost mode or selected speed until the cycle is complete. After the defrost cycle is complete the HRV defaults to previous settings. If the cycle is complete and the thermistor continues to measure defrost temperature the defrost cycle is repeated.

Recirculating Damper Defrost (HRV3-095, HRV3-150-TPD, HRV5-150, HRV5-200-TPD)

During defrost a motor driven damper door mechanism closes off the supply air from outside allowing exhaust air to recirculate through the unit's core. During defrost cycle no ventilation is occurring. After the defrost period, the damper operates in the opposite direction to reopen the fresh air port. Defrost cycle repeats until the temperature rises above 27°F.

Damper Defrost (HRV3-195, HRV3-300 Models)

During defrost a motor driven damper door mechanism closes off the supply air from outside allowing the fifth port to open, enabling warm room air to be drawn in from around the unit. During defrost cycle stale air exhaust is still occurring. After the defrost period, the damper operates in the opposite direction to reopen the fresh air port. Defrost cycle repeats until the temperature rises above 27°F. The defrost port can also be ducted to another location.

Fan Defrost (HRV3-150-TPF)

During the defrost cycle, the supply air motor shuts off, allowing the unit to operate in exhaust only mode. The warm exhaust air will defrost the core. After the defrost cycle has ended, the unit will resume normal operation. Defrost cycle repeats until the outdoor temperature rises above 27°F.

CABINET

Constructed of 20 gauge pre-painted quartz gray steel.

Interior is lined with foil-faced polystyrene to eliminate noise, condensation and air loss.

Cabinet is designed for structural strength and long life.

Access panels are hinged, have quick release latches and can be completely removed for easy access to filters and core(s) for servicing.

Safety interlock switch automatically shuts off power to unit when access panel is opened.

Threaded inserts with screws are furnished on cabinet for hanging unit with furnished PVC reinforced polyester rubber straps.

Condensate drain pans have drain connection (HRV models).

System Balancing

HRV3-150-TPD, HRV3-150-TPF, HRV5-150, HRV5-200-TPD, ERV3-150 and ERV3-200 models include a patented, balancing damper located in the intake and exhaust air stream collar.

HRV3-150-TPD, HRV3-150-TPF, HRV5-150 and HRV5-200-TPD models include door port balancing capability. See installation instructions.

HRV3-095, HRV3-195, HRV3-300 models requires an optional field installed butterfly damper for system balancing. See Optional Accessories.

FEATURES

AIR FILTER

MERV 4 air filters are furnished in both exhaust and intake air streams.

Foam filters are easily removed for cleaning.

Design and location of filters allows maximum filtration with minimum air resistance.

ELECTRICAL

Control Box

Contains control circuit board and auto-transformer.

Plug-in Electrical Connection

Convenient 36 inch (approx. length) power cord with 3-prong 120VAC plug provided for easy electrical connection.

CONTROLS

Circuit Board

Circuit board controls unit operation.

Two jumpers furnished on control board.

One jumper enables/disables recirculating mode.

One jumper overrides normal defrost settings (setting: 27°F /3 min. recirculate, 25 min. ventilation).

Up to five blower speeds and four modes of operation are available with optional wall mount controls.

Self-Test

When unit is energized, the HRV/ERV cycles through all speeds available, tests damper motor operation, and returns to the previous operational mode and speed selection.

Dehumidistat Disable Feature

The dehumidistat function will be disabled if the outdoor temperature exceeds 59°F for a 24-hour period.

The dehumidistat function will be re-enabled if the unit is unplugged for 3 minutes or if the outdoor temperature drops below 59°F for a 24-hour period. Permanently enabled on ERV units.

Furnace/Air Handler Interlock Capability

Built-in function on circuit board allows unit to operate whenever furnace or air handler is operating.

Refer to Installation Instructions for interlocking unit to furnace or air handler.

Terminal Block

Control Board is wired to external terminal block located on side of unit.

Terminal block allows connection to various wall mount controls. See Optional Accessories for complete listing.

Terminal block also allows interlock control connection to furnace or air handler.



Wall Mount Dehumidistat/Ventilation Control (HRV3/HRV5)

HRV Ventilation System Control included with the HRV unit.

NOTE - All GDX models (Canada only) have a Digital 2 Speed / 4 Mode Control furnished as standard. See next page for description.

- ON/OFF button with indicator LED
- Dehumidistat with graduated LED indicators
- Service indicator LED with reset button
- 3-wire, 20-gauge (min.), low-voltage wire connection
- Slim-line design



Wall Mount Ventilation Control (ERV3)

ERV Ventilation System Control included with the ERV unit.

- ON/OFF button with indicator LED
- Service indicator LED with reset button
- 3-wire, 20-gauge (min.), low-voltage wire connection
- Slim-line design



OPTIONAL ACCESSORIES (MUST BE ORDERED SEPARATELY)

CONTROLS

¹ Digital 2 Speed / 4 Mode Control

Fully digital control determines when and how much fresh air will enter the home.

- 2-speed blower setting: 1 (Low), 2 (High)
- Standby setting (blower speed 0)
- Electronic dehumidistat
- Four selectable modes of operation:
 4. **Continuous Ventilation**
 5. **20 min. On / 40 min. Off**
 6. ² **20 min. On / 40 min. Recirculate**
 7. ² **Continuous Recirculation**



- 20 / 40 / 60 high speed override button
- Instruction card inserted in control
- Easy-to-read LCD screen
- 3-wire, 20-gauge (min.), low-voltage wire connection.
- Slim-line design

¹ Furnished as standard with all GDX (Canada only) models.

² NOTE - Recirculation mode not available on all models.

Digital Programmable 5 Speed / 4 Mode Control

Fully digital control allows programming for time of day settings and amount of fresh air entering the home.

- 24/7 programmable ventilation
- 4 programmable events per day (WAKE, LEAVE, ARRIVE, SLEEP)
- Five speed blower settings: 1 (low), 2 (med-low), 3 (med), 4 (med-high), 5 (high)
- Electronic dehumidistat
- Four selectable modes of operation:
 1. **Continuous Ventilation**
 2. **20 min. On / 40 min. Off**
 3. ¹ **20 min. On / 40 min. Recirculate**
 4. ¹ **Continuous Recirculation**



- 20 / 40 / 60 high speed override button
- Service/Maintenance reminder display
- Easy-to-read, backlit LCD screen

¹ NOTE - Recirculation mode not available on all models.

20 / 40 / 60 Minute Timer

Remotely located timer allows 20, 40 or 60 minute operation.

- One-touch button activates high speed.
- 3 indicator LED's show timer status.
- Lockout feature eliminates tampering.
- 3-wire, 20-gauge (min.), low-voltage wire connection.
- Installs in a standard 2 x 4 in. electrical box.



AIR BALANCING TOOLS

Optional Accessories

Butterfly Balancing Damper

6 or 7 in. diameter.



Backdraft Damper

5 or 6 in. diameter. Spring-loaded damper is installed on the Stale Air to Outside ducting. See System Applications.

Door Port Gauge Tube Set

(HRV3-150-TPD/TPF, HRV5-150, HRV5-200-TPD Models Only)

Includes two connection hoses and two rubber fittings and instructions.

Magnehelic gauge or digital manometer (reading down to 0 with resolution of 0.001 in. w.g.) is not furnished and must be field supplied.



OPTIONAL ACCESSORIES (MUST BE ORDERED SEPARATELY)

AIR BALANCING TOOLS (continued)

Digital Manometer

Measures positive, negative or differential pressures of air and gasses. Range: 0-4.000" w.c., max. pressure 5 psig.

Large easy to read LCD display.

Lightweight, extruded aluminum case.

Standard 9-volt battery operation (furnished).

Low battery indicator.

Piezoresistive pressure sensor

Standard dual size connectors (1/8 in. or 3/16 in.)



DUCTWORK

Optional Accessories

Duct Heaters

Duct heaters are available to temper incoming fresh air after heat recovery. Heaters have built-in electronic modulating controller and air flow/temperature sensor to proportionally adjust the heating load to match the exact capacity required while minimizing operating costs.

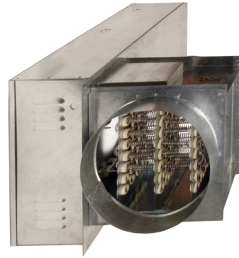

Available in 6 inch (1 or 2 kW) and 7 inch (2 kW) diameter sizes.

Voltage/Phase - 120/1.

H x W x L - 8-1/2 x 11-1/2 x 12-1/2 in.

Flexible Ducts - Insulated or Non-Insulated

Non-insulated ducts are available for connection to optional circular grilles.

Constructed of aluminum foil/ polyester laminate and metalized polyester film around a steel wire helix.



Fully insulated fiberglass ducts have an "R" value of 5.8 and are available for connection to optional outside weatherhoods.

Available for inside use in standard 3 to 10 in. diameters and 25 ft. lengths.

Underwriter's Laboratories Canada (ULC) listed Class 1 Duct.

Hinged Kitchen Exhaust Grille

Louvered panel is hinged for easy access to washable aluminum grease filter.

Size - 6 x 10 in. in white.



Round Diffusers

White molded plastic grilles are available for room air distribution.

Grilles are adjustable for room to room system balancing.

Compression spring tab clips into round duct.

Available in 4, 5, 6 and 8 inch diameters.



Weatherhood Kit

Two furnished per kit, one for intake air and one for exhaust air. Labeled for easy identification.

Fully adjustable for different wall thickness.

Complete with 1/4 in. mesh bird screen, two 12 in. sleeves with insulating duct collars.

Hinged hood allows easy cleaning of screen.

White finish. Available in 5, 6, and 7 inch diameters.



Dual Hood

Dual Hood only requires a single 6 inch diameter penetration in the exterior wall for the fresh air intake and stale air exhaust connections.

Stale air is exhausted from the front of the hood while fresh air intake is from the bottom of the hood.

See dimension drawing on page 15.

See pressure drop charts on page 12.



APPLICATION MAP

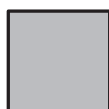
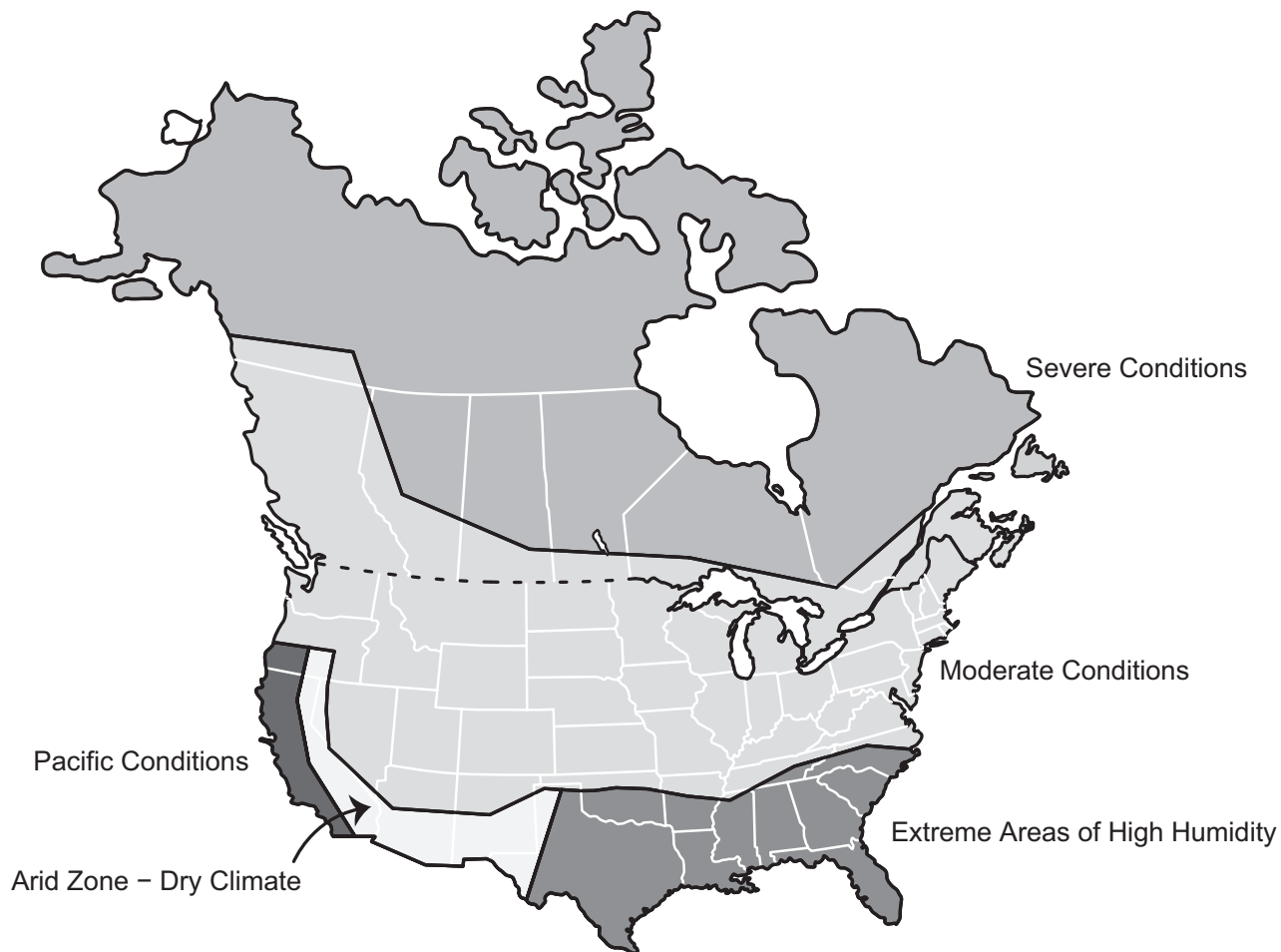

Severe Conditions
HRV Required



Moderate Conditions
HRV Recommended



Pacific Conditions
HRV Recommended
ERV Optional



Arid Zone - Dry Climate
HRV Recommended



*** Extreme Areas of High Humidity**
ERV Recommended

NOTE - ERV is not recommended where temperatures fall below 25°F continuously for more than 5 days.

***ERV is not recommended in regions where high outdoor humidity causes air conditioning operation for dehumidification more frequently than heating system operation**

SYSTEM SIZING

SIZING A CENTRAL VENTILATION SYSTEM

The HRV and ERV is part of a central ventilation system. The system can include multiple fans such as kitchen range hoods and bathroom exhaust fans in addition to the HRV or ERV.

An HRV can be used in place of a bathroom exhaust fan and provide supplemental ventilation in the kitchen (it cannot be used as a range hood). Therefore determining the required Ventilation CFM will depend on the application and standard/method used for calculation.

Method #1

Size the HRV/ERV to provide 1/3 air change per hour - International Residential Code (IRC) 2006

This method requires determining the volume of the home and then providing enough air flow to have one complete air change every 3 hours.

Example: A home has 2000 square feet of conditioned floor space and 8 ft. ceilings.

The volume is $2000 \times 8 = 16,000$ cubic feet. To obtain required airflow in CFM, multiply by 1/3 and divide by 60 minutes/hour: Required airflow, cfm = $16,000 \text{ cu. ft.} \times 1/3 \text{ ACH} / 60 \text{ minutes/hr} = 88 \text{ cfm}$

Method #2

Use a Room Count to find the required airflow - CSA-F326

Determine the number of bedrooms and add 1. Multiply this by 10 cfm. An additional 10 cfm is required for every other room in the house. An unfinished basement requires 20 cfm.

Example: A home with 4 bedrooms, 2 bathrooms, living room, kitchen, dining room and basement requires 110 cfm.

Method #3

ASHRAE (American Society of Heating Refrigeration and Air Conditioning Engineers) Standard 62.2 -2013

This standard describes the minimum ventilation required based on the ASHRAE 4.1a Quick Reference Chart.

Example a 2000 square foot home with 4 bedrooms from ASHRAE 4.1 a quick reference chart predicts 98 CFM.

Method #4

Home Ventilating Institute (HVI):

HVI recommends using the minimum ventilation rate as specified by ASHRAE 62.2 and adding 2 cfm/100 sq.ft. of floor area.

Example a 2000 square foot home with 4 bedrooms from ASHRAE 4.1a Quick Reference Chart predicts 98 CFM + 40 CFM = 138 CFM.

WHOLE BUILDING VENTILATION AIR REQUIREMENTS
ASHRAE 4.1a (I-P) Quick Reference Chart

Floor Area sq. ft.	No. of Bedrooms				
	1	2	3	4	5
	cfm	cfm	cfm	cfm	cfm
<500	30	38	45	53	60
501 - 1000	45	53	60	68	75
1001 - 1500	60	68	75	83	90
1501 - 2000	75	83	90	98	105
2001- 2500	90	98	105	113	120
2501 - 3000	105	113	120	128	135
3001 - 3500	120	128	135	143	150
3501 - 4000	135	143	150	158	165
4001 - 4500	150	158	165	173	180
4501 - 5000	165	173	180	188	195

SYSTEM SIZING

Method #5

Custom method to achieve a target VOC's level in homes

Ventilation or source control may be required above the ASHRAE rates if there are significant sources; or to achieve specific concentration level(s) of chemical(s) of interest [for instance achieving $<20 \text{ ig/m}^3$ of formaldehyde (HCHO) as recommended by the CDC/HUD and NIOSH for occupied trailers]. If ventilation rates other than mentioned above are desired, dealers may wish to obtain the services of a certified IAQ consultant to obtain guidance and laboratory measurements of chemical(s) of concern both before and after installation and operation of additional ventilation to insure that the target concentration(s) of chemical(s) of concern are achieved. Dealers and homeowner need to be aware that reaching specific concentration target(s) may be an iterative process. For instance if there are multiple furnace/air handlers in the home, ventilation may be added to one or more of the indoor units to start with, and if the desired level(s) of chemical(s) of concern are not obtained, additional ventilation can be added to the additional indoor units or more rigorous source control measures implemented (i.e. removing contaminant sources from the home). One option is to size the HRV/ERV based on low speed fan operation or 20 minute/hour operation to one of the above methods which will allow ventilation to be easily increased by changing a controller setting if desired.

NOTE - Dealer should always calculate increased load requirement due to ventilation and insure that HVAC system is sized appropriately to handle both sensible (temperature) and latent (humidity) loads.

Note - In some locations, a standalone dehumidifier may be required to handle the increased latent (humidity) load to prevent increased humidity in the home.

SIZING A CENTRAL VENTILATION SYSTEM

SUMMARY OF THE ABOVE CALCULATIONS USING VARIOUS METHODS

Method 1 - Cubic Volume - 88 CFM

Method 2 - Room Count - 110 CFM

Method 3 - ASHRAE 62.2 - 98 CFM

Method 4 - HVI Recommendation - 1138 CFM

Method 5 - Custom calculation. Size on one of above methods on low speed fan or 20 minute/hour operation. After measuring chemical(s) of concern, adjust operation accordingly.

All methods were calculated using the same 2,000 sq. ft. with 8 ft. ceiling house as an example. Choose the CFM which satisfies the code requirement of your area and application

All sizing is done based on HIGH fan speed data but normal operation is constant LOW fan speed with times of HIGH fan speed from a timer, dehumidistat or wall control

Typically a 0.4 in. w.g. static is used for choosing the correct model (however your duct design would negate the static you want to use for the calculated CFM) for your installation design, see exact model specifications for details (HVI certified data for the unit). It is always recommended a proper duct design is done.

NOTE - Dealer should always calculate increased load requirement due to ventilation and insure that HVAC system is sized appropriately to handle both sensible (temperature) and latent (humidity) loads.

NOTE - In some locations, a standalone dehumidifier may be required to handle the increased latent (humidity) load to prevent increased humidity in the home.

SPECIFICATIONS - HRV

		Model No.	HRV3-095	HRV5-150	HRV3-150-TPD	HRV3-150-TPF
			¹ HRV3-095-GDX	¹ HRV5-150-GDX	¹ HRV3-150-TPD-GDX	¹ HRV3-150-TPF-GDX
ENERGY STAR® Qualified (Canada Only)		No. of Cores	Single	Single	Single	Single
Performance	Sensible effectiveness @ 32°F		88% (60 cfm)	84% (59 cfm)	74% (66 cfm)	75% (66 cfm)
	Sensible efficiency (thermal) @ 32°F		75% (60 cfm)	75% (59 cfm)	61% (66 cfm)	66% (66 cfm)
	Sensible efficiency (thermal) @ -13°F		68% (61 cfm)	72% (64 cfm)	63% (76 cfm)	56% (76 cfm)
Blower	Air Flow (cfm)	0.1 in. w.g.	76	184	169	174
	vs. Static Pressure	0.2 in. w.g.	73	163	156	165
	(high speed)	0.3 in. w.g.	70	146	149	154
	(HVI Certified)	0.4 in. w.g.	66	132	136	143
		0.5 in. w.g.	60	115	126	132
		0.6 in. w.g.	---	92	116	120
		0.7 in. w.g.	---	60	103	107
		0.8 in. w.g.	---	---	89	95
Number of Speeds Available (with furnished control)			2	2	2	2
Number of Speeds Available (with optional control)			5	5	5	5
Defrost type			Recirculating	Recirculating	Recirculating	Fan
Door Port Balancing			No	Yes	Yes	Yes
Balancing Damper in Intake and Exhaust Collar			No	Yes	Yes	Yes
Duct Ports	Connections (No.) & diameter - inch		(2) 5 outside	(2) 6 outside	(2) 5 outside	(2) 5 outside
			(2) 6 inside	(2) 6 inside	(2) 5 inside	(2) 5 inside
Condensate drain (o.d.) - in. (includes tee)			(2) 1/2	(2) 1/2	(2) 1/2	(2) 1/2
Shipping weight - lbs.			56	73	54	54

ELECTRICAL DATA

	Voltage	120 volts - 60 hertz - 1 phase			
Blower HP (PSC type)		1/20	1/10	1/20	1/20
Fan Watts - high speed @ 0.3 in. w.g.		150	118	110	118
Fan Watts - low speed @ 0.3 in. w.g.		60	66	57	66
Amp Rating		0.9	1.4	1.3	1.4

NOTE - Effectiveness is based on temperature difference between the 2 airstreams. Efficiency includes parasitic losses from fan operation.

¹ Canada only.

SPECIFICATIONS - HRV

		Model No.	HRV5-200-TPD	HRV3-195	HRV3-300
			¹ HRV5-200-TPD-GDX		
ENERGY STAR® Qualified (Canada Only)		No. of Cores	Single	Dual	Dual
Performance	Sensible effectiveness @ 32°F		77% (100 cfm)	86% (114 cfm)	90% (117 cfm)
	Sensible efficiency (thermal) @ 32°F		68% (100 cfm)	78% (114 cfm)	79% (117 cfm)
	Sensible efficiency (thermal) @ -13°F		68% (100 cfm)	72% (112 cfm)	70% (132 cfm)
Blower	Air Flow (cfm)	0.1 in. w.g.	222	216	232
	vs. Static Pressure	0.2 in. w.g.	207	195	212
	(high speed)	0.3 in. w.g.	193	181	202
	(HVI Certified)	0.4 in. w.g.	179	158	183
		0.5 in. w.g.	165	144	163
		0.6 in. w.g.	150	125	144
		0.7 in. w.g.	135	107	123
		0.8 in. w.g.	119	72	92
Number of Speeds Available (with furnished control)			2	2	2
Number of Speeds Available (with optional control)			5	5	5
Defrost type			Recirculating	Damper	Damper
Door Port Balancing			Yes	No	No
Balancing Damper in Intake and Exhaust Collar			Yes	No	No
Duct Ports	Connections (No.) & diameter - inch		(2) 6 outside	(2) 6 outside	(2) 6 outside
			(2) 6 inside	(2) 7 inside (1) 6 defrost	(2) 7 inside (1) 6 defrost
Condensate drain (o.d.) - in. (includes tee)			(2) 1/2	(2) 1/2	(2) 1/2
Shipping weight - lbs.			67	108	108

ELECTRICAL DATA

	Voltage	120 volts - 60 hertz - 1 phase		
Blower HP (PSC type)		1/10	1/10	1/4
Fan Watts - high speed @ 0.3 in. w.g.		96	173	333
Fan Watts - low speed @ 0.3 in. w.g.		64	64	150
Amp Rating		1.4	1.5	2.9

NOTE - Effectiveness is based on temperature difference between the 2 airstreams. Efficiency includes parasitic losses from fan operation.

¹ Canada only.

SPECIFICATIONS - ERV

		Model No.	ERV3-150	ERV3-200
		Number of Cores	Single	Single
Performance	Sensible effectiveness @ 32°F		81% (63 cfm)	76% (116 cfm)
	Sensible efficiency (thermal) @ 32°F		69% (63 cfm)	69% (116 cfm)
	Latent efficiency (moisture) 95°F		37% (65 cfm)	41% (117 cfm)
	Total efficiency 95°F		47% (65 cfm)	50% (117 cfm)
Blower	Air Flow (cfm)	0.1 in. w.g.	151	180
	vs. Static Pressure (high speed)	0.2 in. w.g.	141	169
		0.3 in. w.g.	132	157
		0.4 in. w.g.	124	146
		0.5 in. w.g.	107	132
		0.6 in. w.g.	98	118
		0.7 in. w.g.	81	101
		0.8 in. w.g.	60	82
		Number of Speeds Available (with furnished control)		1
	Number of Speeds Available (with optional control)		5	5
Door Port Balancing			No	No
Balancing Damper in Intake and Exhaust Collar			Yes	Yes
Duct Ports	Connections (No.) & diameter - inch		(2) 6 outside, (2) 6 inside	(2) 6 outside, (2) 6 inside
ELECTRICAL DATA				
		Voltage	120 volts - 60 hertz - 1 phase	
		Blower HP (PSC type)	1/20	1/10
		Fan Watts - high speed @ 0.3 in. w.g.	173	182
		Fan Watts - low speed @ 0.3 in. w.g.	63	70
		Amp Rating	1.4	1.4
Shipping weight - lbs. (kg)			70 (32)	70 (32)

NOTE - Effectiveness is based on temperature difference between the 2 airstreams.
Efficiency includes parasitic losses from fan operation

OPTIONAL ACCESSORIES - ORDER SEPARATELY

Model No.		HRV3-095	HRV3-150-TPD/TPF	HRV5-150	HRV5-200-TPD	HRV3-195	HRV3-300	ERV3-150	ERV3-200
Air Balancing Tools									
Door Port Gauge Tube Set		N/A	Y2207	Y2207	Y2207	N/A	N/A	N/A	N/A
Digital Handheld Manometer		Y6484	Y6484	Y6484	Y6484	Y6484	Y6484	Y6484	Y6484
Backdraft Damper	5 in. diameter	Y3728	Y3728	---	---	---	---	---	---
	6 in. diameter	---	---	Y3727	Y3727	Y3727	Y3727	Y3727	Y3727
Butterfly Damper	6 inch diameter	91X09	Furnished	Furnished	Furnished	---	---	Furnished	Furnished
	7 inch diameter	---	---	---	---	Field Provided	Field Provided	---	---
Controls	Five Speed PGM Controller	Y2172	Y2172	Y2172	Y2172	Y2172	Y2172	Y2172	Y2172
	Two Speed, Four Mode Digital Control	Y2171	Y2171	Y2171	Y2171	Y2171	Y2171	Y2171	Y2171
	20/40/60 Minute Fan Timer	Y2169	Y2169	Y2169	Y2169	Y2169	Y2169	Y2169	Y2169
¹ Dual Hood		Y3813	Y3813	Y3813	Y3813	Y3813	N/A	Y3813	Y3813
Duct Heaters	6 in. diameter (1 kW)	97E73	97E73	97E73	97E73	97E73	97E73	97E73	97E73
	6 in. diameter (2 kW)	20N16	20N16	20N16	20N16	20N16	20N16	20N16	20N16
	7 in. diameter (2 kW)	97E74	97E74	97E74	97E74	97E74	97E74	97E74	97E74
	Voltage/Phase (60 Hz)	120/1	120/1	120/1	120/1	120/1	120/1	120/1	120/1
	Amps - 1 kW Heater	8.3	8.3	8.3	8.3	8.3	8.3	8.3	8.3
	Amps - 2 kW Heaters	16.7	16.7	16.7	16.7	16.7	16.7	16.7	16.7
² Flexible Ducts - No. & dia. - in.		(2) 5	(2) 5	(2) 6	(2) 6	(2) 6	(2) 6	(2) 6	(2) 6
Hinged Kitchen Exhaust Grille		18N48	18N48	18N48	18N48	18N48	18N48	18N48	18N48
Round Diffusers	4 in. diameter	92E54	92E54	92E54	92E54	92E54	92E54	92E54	92E54
	5 in. diameter	92E55	92E55	92E55	92E55	92E55	92E55	92E55	92E55
	6 in. diameter	92E56	92E56	92E56	92E56	92E56	92E56	92E56	92E56
	8 in. diameter	56N81	56N81	56N81	56N81	56N81	56N81	56N81	56N81
³ Weatherhood Kit (2 per kit)	5 in. diameter	92E66	92E66	92E66	92E66	92E66	92E66	92E66	92E66
	6 in. diameter	95P07	95P07	95P07	95P07	95P07	95P07	95P07	95P07
	7 in. diameter	17N11	17N11	17N11	17N11	17N11	17N11	17N11	17N11

¹ See Pressure Drop Charts below for application.

² Contact your Territory Manager for additional information.

³ Two Required, one for fresh air intake, one for stale air exhaust.

DUAL HOOD PRESSURE DROP/AIRFLOW CHARTS

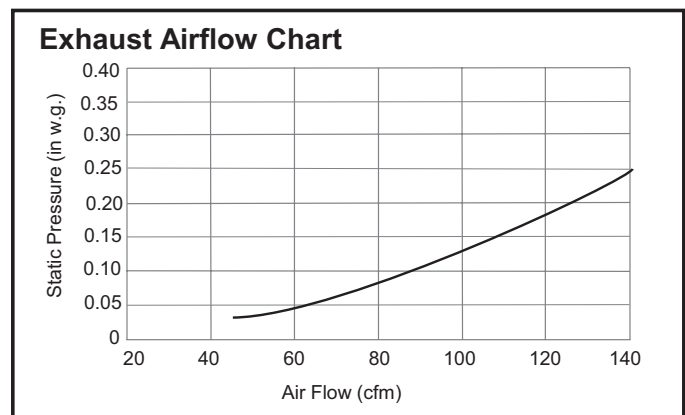
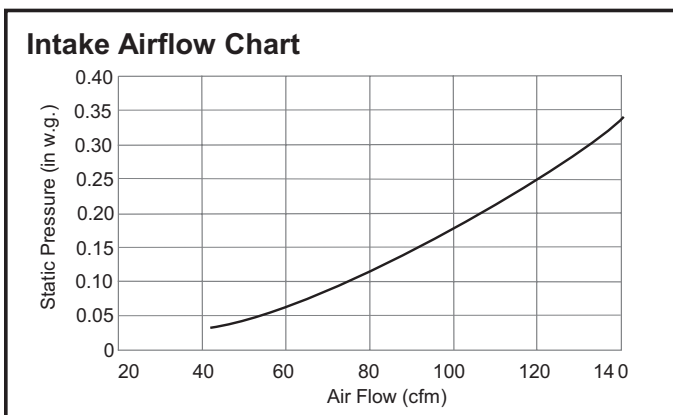

BLOWER DATA

FOR OPTIONAL CONTROLS (Factory Tested)

		Model No.	HRV3-095	HRV3-150 -TPD/TPF	HRV5-150	HRV5-200- TPD	HRV3-195	HRV3-300	ERV3-150	ERV3-200
Speed 4 Medium-High	Air Flow (cfm) vs. Static Pressure	0.1 in. w.g.	70	---	153	189	167	220	120	180
		0.2 in. w.g.	65	---	141	170	159	202	111	169
		0.3 in. w.g.	50	---	131	153	150	186	103	157
		0.4 in. w.g.	31	101	117	136	140	169	92	146
		0.5 in. w.g.	---	91	96	120	124	158	80	132
		0.6 in. w.g.	---	82	80	106	110	134	84	118
		0.7 in. w.g.	---	69	---	91	93	108	43	101
		0.8 in. w.g.	---	60	---	78	---	79	---	82
Speed 3 Medium	Air Flow (cfm) vs. Static Pressure	0.1 in. w.g.	65	---	144	161	142	194	97	133
		0.2 in. w.g.	60	---	130	141	136	178	87	130
		0.3 in. w.g.	48	92	120	123	127	170	81	124
		0.4 in. w.g.	30	82	106	108	118	154	72	114
		0.5 in. w.g.	---	71	88	92	103	139	61	104
		0.6 in. w.g.	---	60	---	77	92	118	53	94
		0.7 in. w.g.	---	---	---	64	72	94	---	80
		0.8 in. w.g.	---	---	---	52	---	---	---	---
Speed 2 Medium-Low	Air Flow (cfm) vs. Static Pressure	0.1 in. w.g.	62	---	127	127	115	170	73	112
		0.2 in. w.g.	54	81	116	108	107	163	67	107
		0.3 in. w.g.	42	70	106	73	100	151	59	101
		0.4 in. w.g.	26	60	97	60	90	136	51	96
		0.5 in. w.g.	---	46	86	48	81	129	45	88
		0.6 in. w.g.	---	---	---	38	66	107	---	77
		0.7 in. w.g.	---	---	---	---	---	88	---	60
Speed 1 Low	Air Flow (cfm) vs. Static Pressure	0.1 in. w.g.	51	---	108	100	88	144	53	88
		0.2 in. w.g.	45	61	100	78	80	137	44	85
		0.3 in. w.g.	33	49	91	60	73	134	38	80
		0.4 in. w.g.	18	35	78	46	63	121	32	77
		0.5 in. w.g.	---	---	---	32	56	110	---	67
		0.6 in. w.g.	---	---	---	---	43	95	---	---

NOTE - See Specifications tables for standard high speed data.

BLOWER DATA WITH OPTIONAL DUAL HOOD

NOTE - Perform all calculations for duct sizing in the usual manner (taking into account measured and equivalent lengths).

Model No.	Airflow (cfm) at Nominal External Static Pressure - in. w.g.			Description
	0.3	0.4	0.5	
HRV3-095	66	60	N/A	Airflow With Dual Hood
HRV3-150-TPD	115	104	95	Airflow With Dual Hood
HRV3-150-TPF	120	107	100	Airflow With Dual Hood
HRV5-150	115	103	87	Airflow With Dual Hood
HRV5-200-TPD	128	120	110	Airflow With Dual Hood
HRV3-195	125	114	107	Airflow With Dual Hood
HRV3-300	N/A	N/A	N/A	Not Available
ERV3-150	107	98	81	Airflow With Dual Hood
ERV3-200	125	118	101	Airflow With Dual Hood

DIMENSIONS - INCHES (MM)

HRV3-095 HEAT RECOVERY VENTILATOR

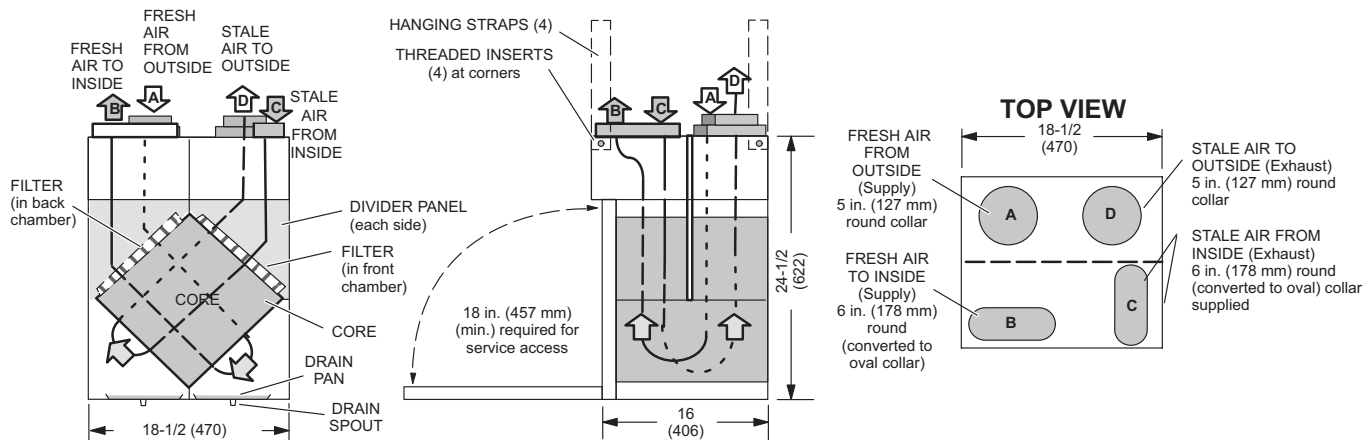

HRV5-150 HEAT RECOVERY VENTILATORS

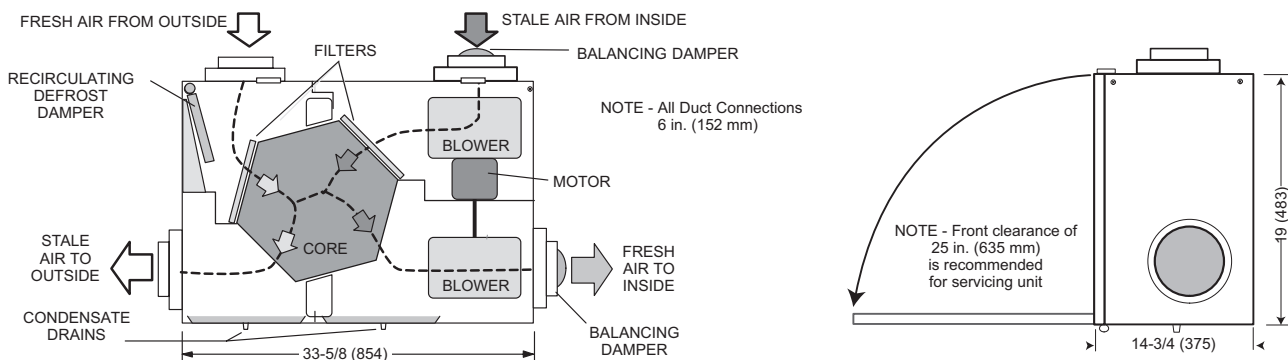

HRV3-195, HRV3-300 HEAT RECOVERY VENTILATORS

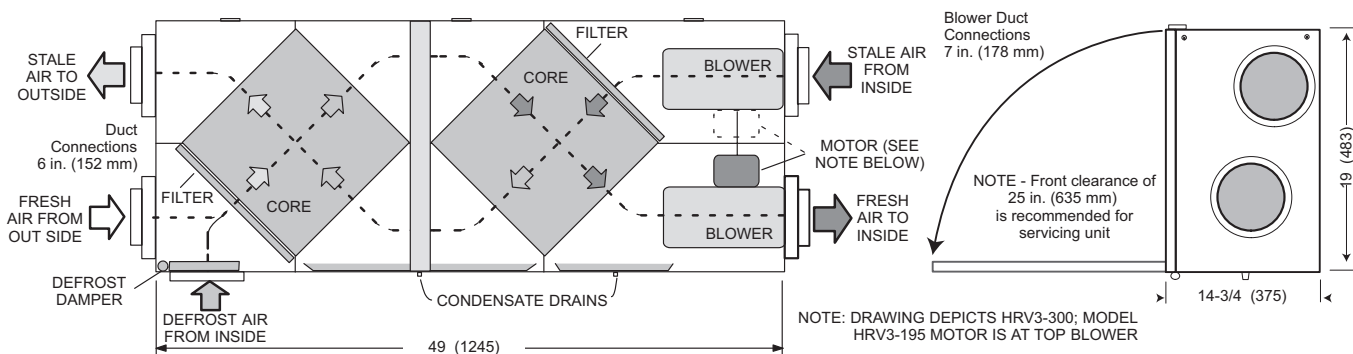

HRV3-150-TPD/TPF HEAT RECOVERY VENTILATORS

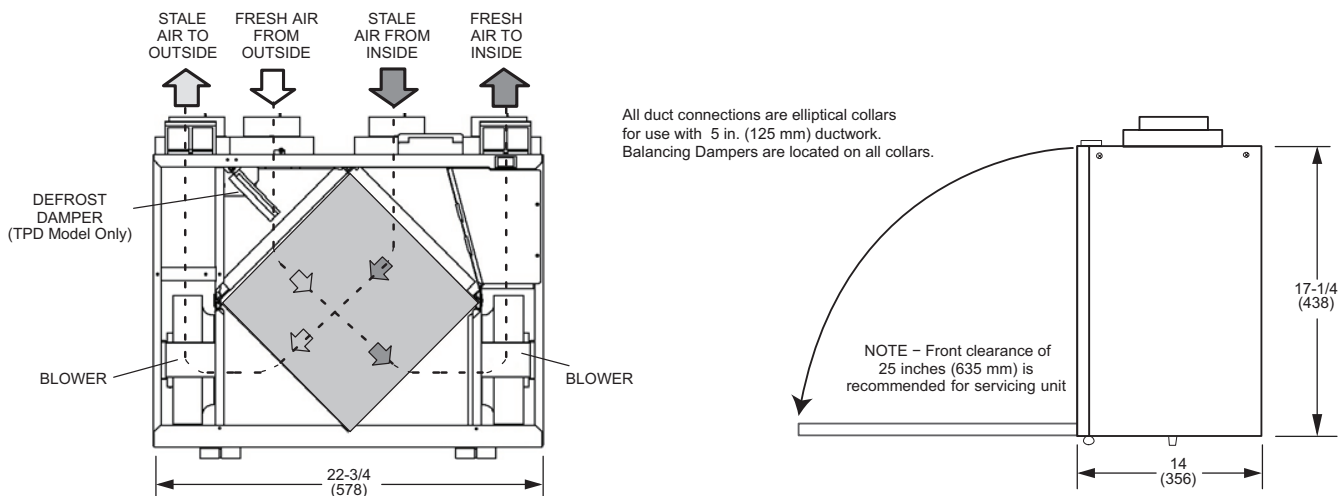

DIMENSIONS - INCHES (MM)

HRV5-200-TPD HEAT RECOVERY VENTILATORS

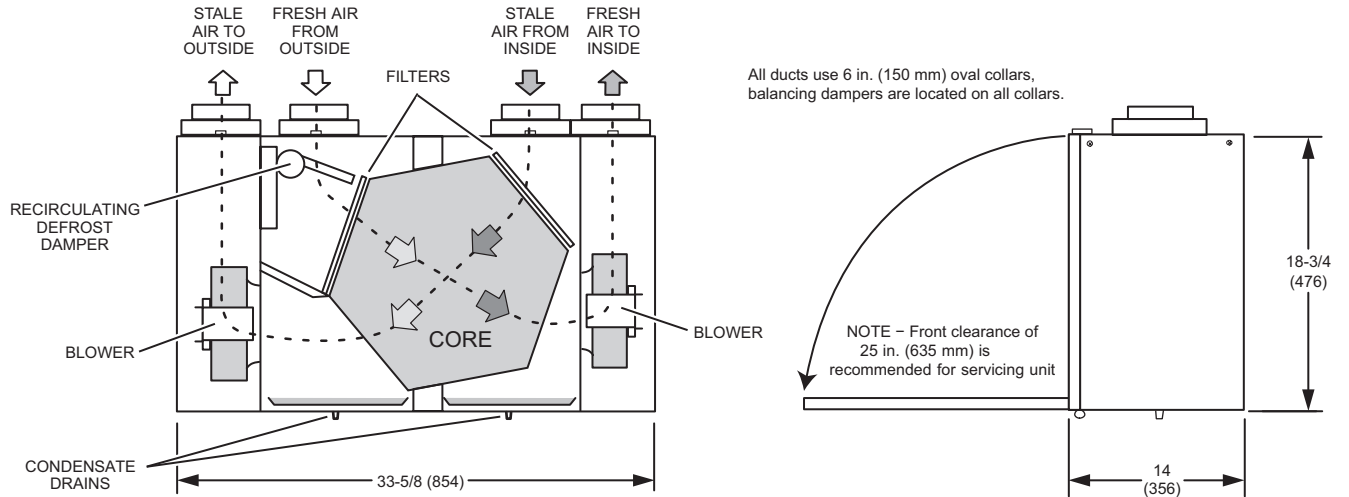

ERV3-150, ERV3-200 ENERGY RECOVERY VENTILATORS

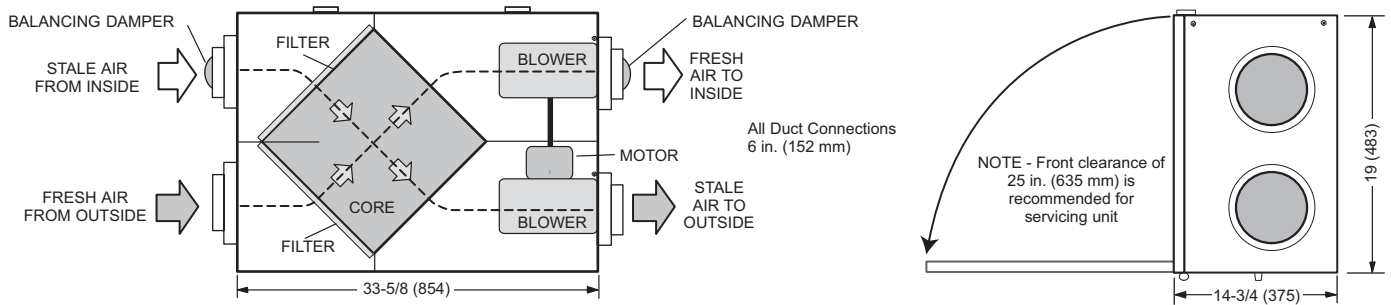

ACCESSORY DIMENSIONS - INCHES (MM)

DUAL HOODS

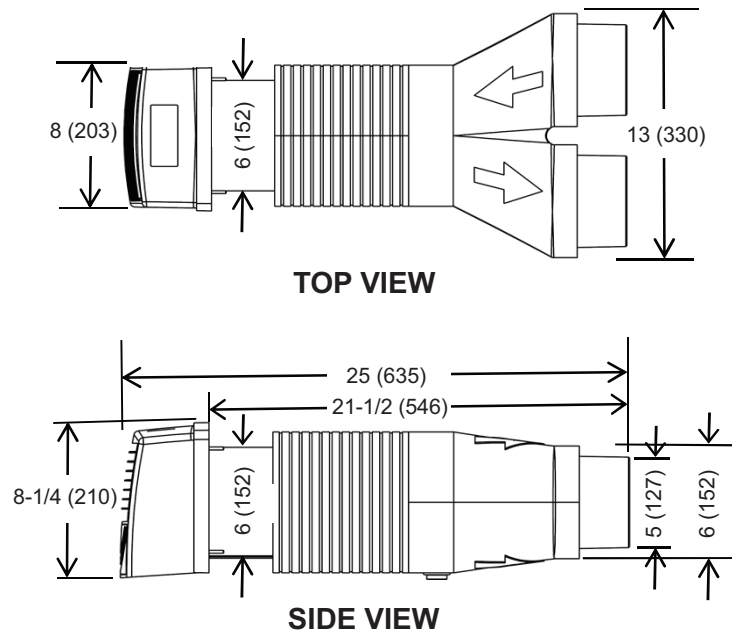

TYPICAL SYSTEM APPLICATIONS

SIMPLIFIED INSTALLATION (Return/Return Method)

(Direct connection of both supply and exhaust air streams to the air handler cold air return)

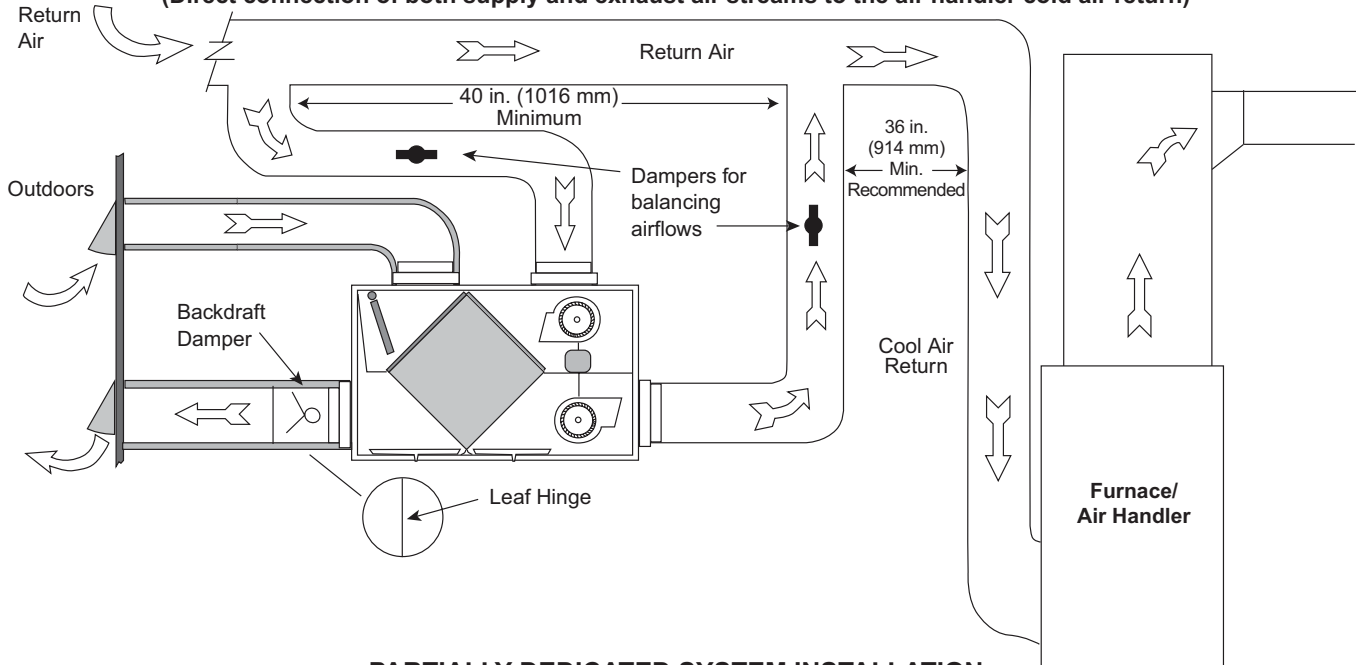

PARTIALLY DEDICATED SYSTEM INSTALLATION

(Direct connection of supply air stream to the air handler cold air return)
(Stale air drawn from key areas of home)

EXHAUST AIR from various parts of home.
(i.e. bathrooms, kitchens, utility areas)

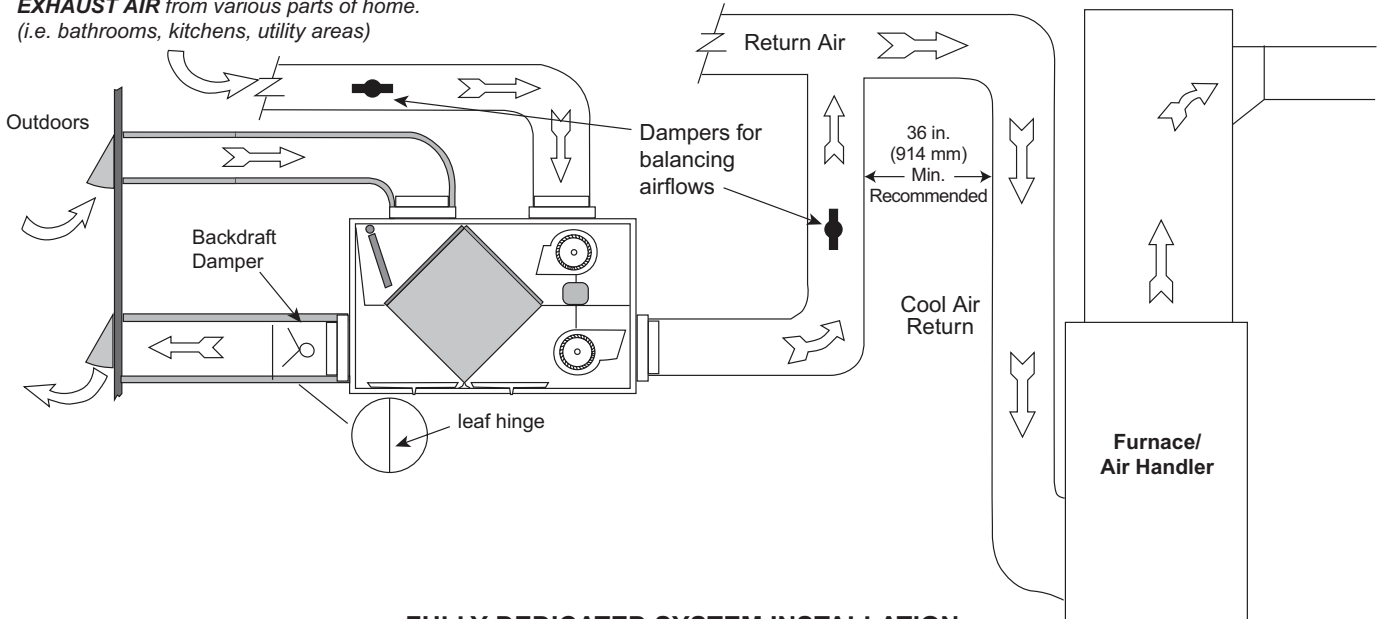

FULLY DEDICATED SYSTEM INSTALLATION

(Fresh air supplied to main living areas of house. Stale air drawn from key areas of home)

Stale air from various parts of home (i.e. bathrooms, kitchens, utility areas)

Fresh air to house - main living areas, bedrooms, living room, rec. room, etc.

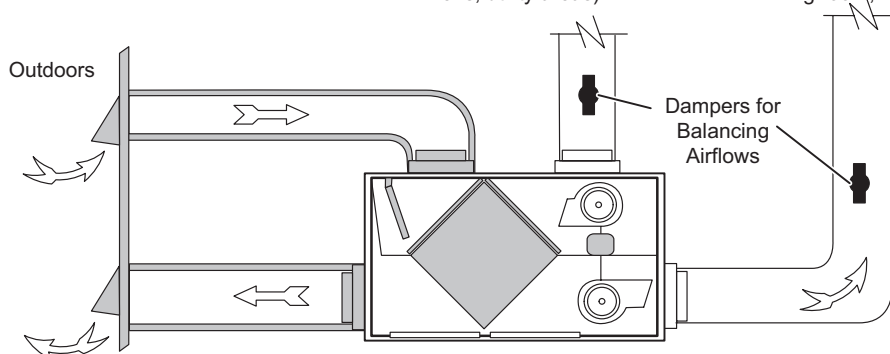

REVISIONS

Sections	Description of Change
Optional Accessories	Pitot Tube and Pitot Tube Air Flow Balancing Kit are discontinued.



Visit us at www.lennox.com

For the latest technical information, www.lennox.com

Contact us at 1-800-4-LENNOX

NOTE - Due to Lennox' ongoing commitment to quality, Specifications, Ratings and Dimensions subject to change without notice and without incurring liability. Improper installation, adjustment, alteration, service or maintenance can cause property damage or personal injury. Installation and service must be performed by a qualified installer and servicing agency.

©2016 Lennox Industries, Inc.