

ENGINEERING DATA

THERMALLY CONDUCTIVE, PATENTED ALUMINUM CORE

The cross-flow heat recovery core transfers heat between the two airstreams. The two cores are arranged for highly efficient counter current airflow.

MOTORS AND BLOWERS

High efficiency electronic commutate ECM motor, for maximum energy savings. Each airstream has one centrifugal blower, with multiple fan speed operations driven by on double shaft motor.

FILTERS

Washable air filters in exhaust and supply airstreams.

MOUNTING THE HRV

Threaded inserts at corners of the cabinet designed to accept the "S" hooks and hanging straps supplied with the unit.

DEFROST

Damper defrost system.

CASE

20 gauge prepainted galvanized steel for superior corrosion resistance, insulated to prevent exterior condensation. Drain connections 2-1/2" (12mm) OD.

ELECTRONICS

Control included with the unit can be wall mounted in a central location of the home. 3 wire 20 gauge (min.) 100 ft length (max.).

CONTROL

99-DXPL02 Lifebreath Digital Control

- 5 speed operation on each mode
- 5 user selectable operational modes: Continuous Ventilation, Continuous Recirculation, 20 ON/40 OFF, 10 ON/50 OFF, 20 ON/40 Recirculation
- Compatible with 99-DET02 Wireless Timers
- Humidity control through adjustable Dehumidistat
- 20/40/60 High speed override button
- 3 wire connection

TIMER OPTIONS

99-DET01 Lifebreath 20/40/60 Minute Timer - Initiates High speed Ventilation for 20, 40 or 60 minutes. 3 wire connection.

99-DET02 WIRELESS Lifebreath 20/40/60 Minute Timer - Initiates High speed Ventilation for 20, 40 or 60 minutes. Wirelessly connects to main control for ease of installation. 40' approximate range.

99-RX02 WIRELESS Repeater - Used to extend range of 99-DET02 Wireless Timers. Plugs into 120V power outlet. Wirelessly connects to main control and 99-DET02. Install at halfway point between timer and main wall control if timer is out of range.

ACCESSORY OPTIONS

99-163 Duct Heater w/Electronic SCR Thermostat - 1 kW, 6 in (152 mm)

99-186 Weatherhoods - Two 6 in (152 mm)

WEIGHT 88 lbs (40 kg) **SHIPPING WEIGHT** 92 lbs (41.8 kg)

DIMENSIONS 195ECM

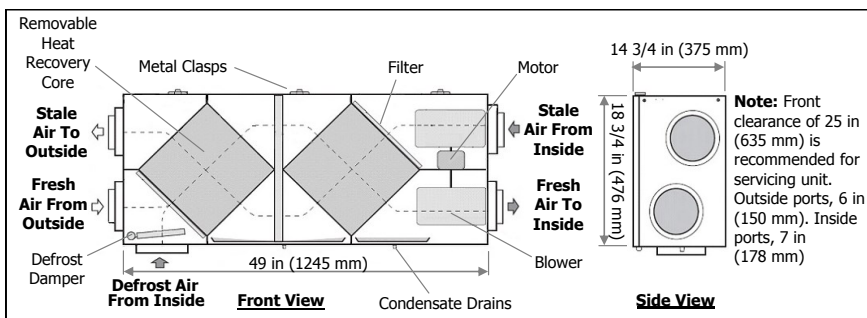

Performance	
Net supply air flow in cfm (L/s) against external static pressure	
External Static Pressure	Airflow
@ 0.1 in (25 Pa)	191 cfm (90 L/s)
@ 0.2 in (50 Pa)	184 cfm (86 L/s)
@ 0.3 in (75 Pa)	177 cfm (83 L/s)
@ 0.4 in (100 Pa)	169 cfm (80 L/s)
@ 0.5 in (125 Pa)	159 cfm (75 L/s)
@ 0.6 in (150 Pa)	152 cfm (71 L/s)
Max. Temperature Recovery	88%
Sensible Effectiveness	
@ 114 cfm (54 L/s) 32°F (0°C)	85%
Sensible Efficiency	
@ 114 cfm (54 L/s) 32°F (0°C)	78%
Sensible Efficiency	
@ 119 cfm (56 L/s) -13°F (-25°C)	69%
VAC @ 60Hz	120
Watts / Low speed	34
Watts / High speed	129
Amp rating	1.7

Sensible Efficiency: Thermal

Effectiveness: Based on temperature differential between the 2 airstreams

Efficiency: Takes into account all power inputs

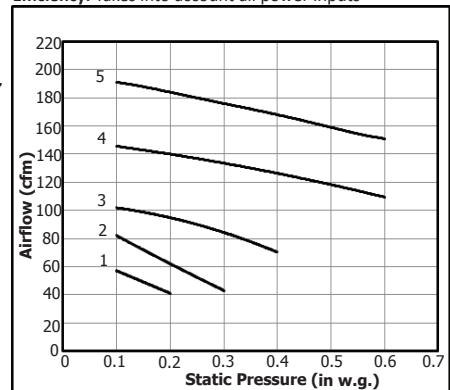

WARRANTY

Units carry a lifetime warranty on the HRV core and a 5 year replacement parts warranty.

NOTE

The ECM motor produces a tone that some may find objectionable. We recommend the installation of the 99-SILENCER6 on the 'Stale Air From Inside' and 'Fresh Air To Inside' ducts.

NOTE: All specifications are subject to change without notice.

All units conform to CSA and UL standards



Date: _____

Tag: _____ Qty: _____

Project: _____

Engineer: _____

Contractor: _____

Supplier: _____

Quote #: _____

Submitted By: _____