

195 DCS HEAT RECOVERY VENTILATOR



ENGINEERING DATA

THERMALLY CONDUCTIVE, PATENTED ALUMINUM CORE

The cross-flow heat recovery core transfers heat between the two airstreams. The two cores are arranged for highly efficient counter current airflow.

MOTORS AND BLOWERS

Each airstream has one centrifugal blower driven by a common PSC motor, with multiple fan speed operations.

FILTERS

Washable air filters in exhaust and supply air streams.

MOUNTING

Four threaded inserts at corners of the cabinet designed to accept the "s" hooks and hanging straps supplied with the unit.

DEFROST

Damper defrost system.

CASE

Twenty gauge prepainted galvanized steel for superior corrosion resistance. Insulated to prevent exterior condensation. Drain connections 2 - 1/2 in. (12 mm) OD. Balancing ports are located on door.

ELECTRONICS

The DXPL02 control included with the unit can be wall mounted in a central location of the home. 3 wire 20 gauge (min.) 100 ft length (max.).

WARRANTY

Units carry a lifetime warranty on the HRV core and a 5 year replacement parts warranty.

OPTIONAL ACCESSORIES:

Weather Hood

99-185
99-186
99-187



TechGrille

99-EAG4
99-EAG5
99-EAG6
99-EAG8



Terminator Fitting

99-TM4
99-TM5
99-TM6



Wireless 20/40/60 Min Timer

99-DETO2



LIFEBREATH CONTROL OPTIONS

FEATURES	99-DXPL02	99-BC02	99-BC03	99-BC04
5 speed fan operation on each mode	✓			
2 speed fan operation (Low/High)		✓		✓
Continuous low speed fan operation			✓	
Humidity control through adjustable Dehumidistat	✓	✓	✓	
Large digital LCD screen	✓			
LED status indicator lights		✓	✓	✓
Continuous Ventilation	✓		✓	
Continuous Recirculation	✓		✓	
20 ON/40 OFF	✓			
10 ON/50 OFF	✓			
20 ON/40 Recirculation	✓		✓	✓
20/40/60 min. High speed override button	✓			
Compatible with 99-DETO2 Wireless Timer	✓	✓	✓	✓
3 wire connection	✓	✓	✓	✓

TIMER OPTIONS

99-DETO1 - Lifebreath 20/40/60 Minute Timer
Initiates high speed Ventilation for 20, 40 or 60 minutes. 3 wire connection.

99-DETO2 Wireless Lifebreath 20/40/60 Minute Timer
Initiates high speed Ventilation for 20, 40 or 60 minutes. Wirelessly connects to main control for ease of installation. 40' approximate range. Exclusive to Lifebreath.

99-RX02 - Wireless Lifebreath Repeater
Extends range of 99-DETO2 Wireless Timers. Plugs into 120V power outlet. Wirelessly connects to main control and 99-DETO2. Install at halfway point between timer and main wall control if timer is out of range.



99-DXPL02



99-DETO2



195 DCS HEAT RECOVERY VENTILATOR



PERFORMANCE (HVI CERTIFIED)

IN. W.G. (PA)	0.1 (25) CFM (L/s)	0.2 (50) CFM (L/s)	0.3 (75) CFM (L/s)	0.4 (100) CFM (L/s)	0.5 (125) CFM (L/s)	0.6 (150) CFM (L/s)	0.7 (175) CFM (L/s)	0.8 (200) CFM (L/s)
Net Supply Airflow	216 (101)	195 (92)	181 (85)	158 (74)	144 (68)	125 (59)	107 (50)	72 (34)
Gross Supply Airflow	229 (108)	207 (97)	193 (91)	168 (79)	153 (72)	133 (63)	114 (53)	76 (36)
Gross Exhaust Airflow	219 (103)	205 (96)	192 (90)	179 (84)	164 (77)	146 (69)	130 (61)	109 (51)

ELECTRICAL SPECIFICATIONS	
VAC @ 60Hz	120
Watts / Low Speed	74
Watts / High Speed	123
Amp Rating	1.5

Sensible Effectiveness (ASE) @ 73 CFM (35 L/s)	32°F (0°C)	92%
Sensible Efficiency (SRE) @ 73 CFM (35 L/s)	32°F (0°C)	82%
Sensible Efficiency (SRE) @ 98 CFM (46 L/s)	32°F (0°C)	78%
Sensible Efficiency (SRE) @ 112 CFM (53 L/s)	-13°F (-25°C)	72%

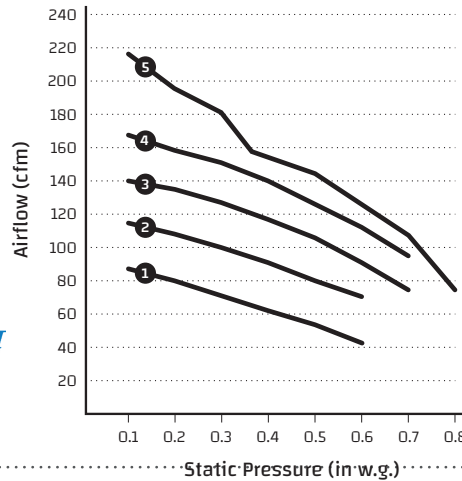

WEIGHT:
88 LBS (40 KG)

SHIPPING WEIGHT:
92 LBS (41.8 KG)

NOTE:

Front clearance of 25 in. (635 mm) is recommended for servicing unit. Outside ports, 6 in. (150 mm). Inside ports, 7 in. (178 mm).



DIMENSIONS

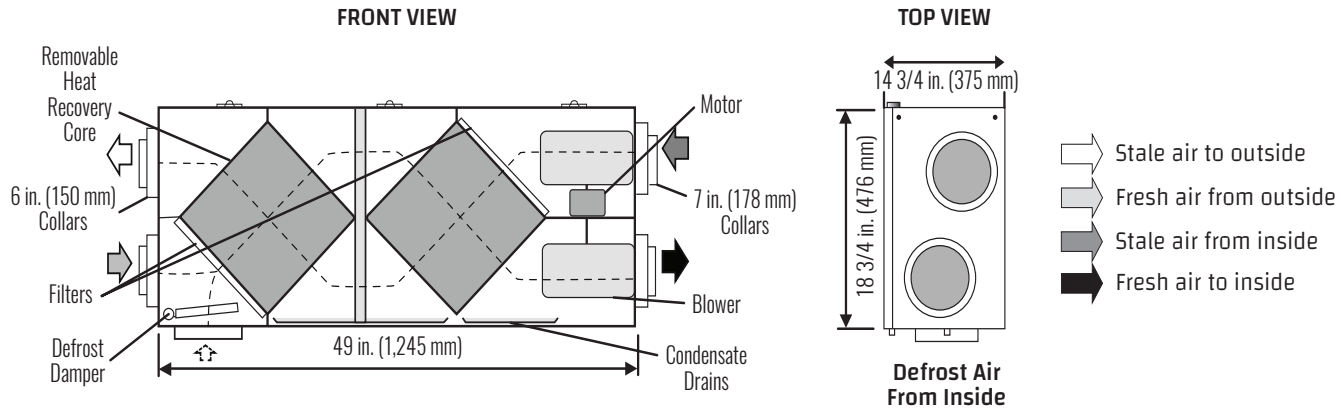

Date: _____

Tag: _____

Project: _____ Qty: _____

Engineer: _____

Control: _____

Contractor: _____

Supplier: _____

Quote #: _____

Submitted By: _____

Timer: _____ Timer Qty: _____

WARRANTY

Units carry a lifetime warranty on the HRV core and a 5 year replacement parts warranty.

All units conform to CSA and UL standards



www.lifebreath.com