

# INSTALLATION GUIDE FOR VENMAR AVS S10 ERV, S10c ERV, S10 ERVPLUS, S10n ERVplus AND VÄNÉE 70E, 70Ec, 70E+ AND 70En+ UNITS

Model nos.: 41700 and 41800

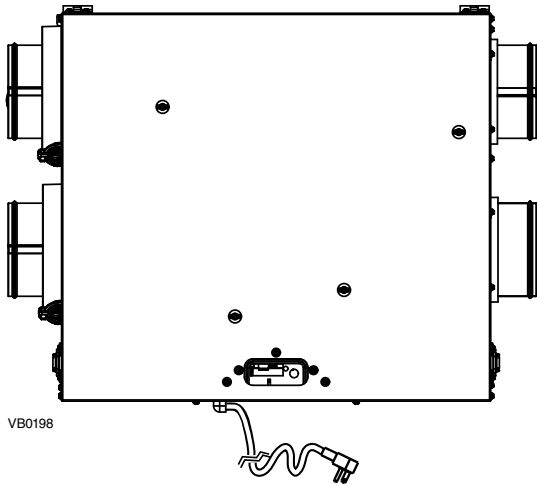

VB0198

Model nos.: 41704 and 41804

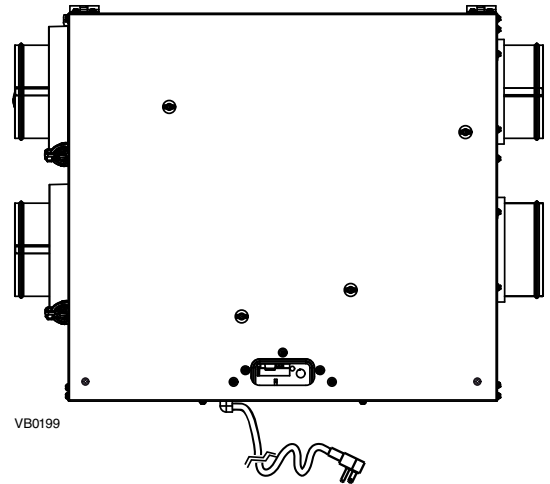

VB0199

Model nos.: 41702\* and 41802\*

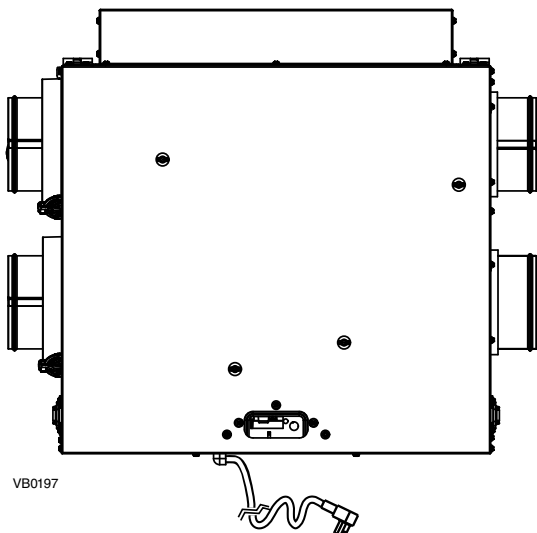

VB0197

Model nos.: 41706\* and 41806\*

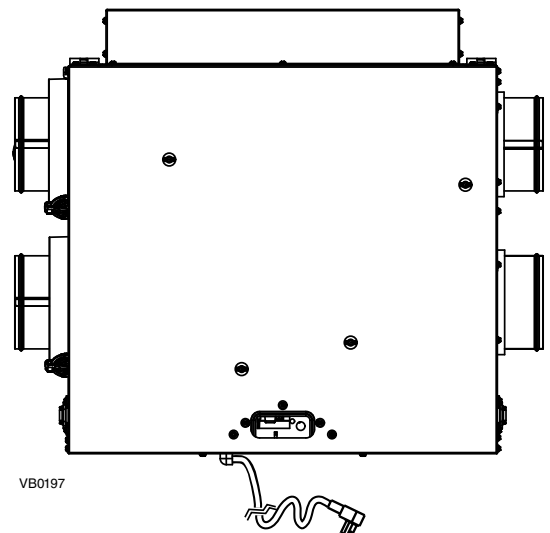

VB0197

**⚠ RESIDENTIAL USE ONLY ⚠**

**READ AND SAVE THESE INSTRUCTIONS**



7 72371 13118 7



\*These products earned the ENERGY STAR® by meeting strict energy efficiency guidelines set by Natural Resources Canada and the US EPA. They meet ENERGY STAR requirements only when used in Canada.

## ABOUT THIS MANUAL

Because of the amount of models covered by this publication, the illustrations are typical ones. Some details of your unit may be slightly different than the ones shown.

Please take note that this manual uses the following symbols to emphasize particular information:

### **⚠ WARNING**

**Identifies an instruction which, if not followed, might cause serious personal injuries including possibility of death.**

### **⚠ CAUTION**

**Identifies an instruction which, if not followed, may severely damage the unit and/or its components.**

NOTE: Indicates supplementary information needed to fully complete an instruction.

## ABOUT THESE UNITS

### LIMITATION

For residential (domestic) installation only. Installation work and electrical wiring must be done by a qualified person(s) in accordance with all applicable codes and standards, including fire-rated construction codes and standards.

### **⚠ WARNING**

#### **TO REDUCE THE RISK OF FIRE, ELECTRIC SHOCK, OR INJURY TO PERSON(S) OBSERVE THE FOLLOWING:**

1. Use this unit only in the manner intended by the manufacturer. If you have questions, contact the manufacturer at the address or telephone number listed in the warranty.
2. Before servicing or cleaning the unit, disconnect power cord from electrical outlet.
3. This unit is not designed to provide combustion and/or dilution air for fuel-burning appliances.
4. When cutting or drilling into wall or ceiling, do not damage electrical wiring and other hidden utilities.
5. Do not use this unit with any solid-state speed control device other than following controls:

UNIT	MAIN CONTROL	AUXILIARY CONTROLS
VENMAR AVS S10 ERV <sup>PLUS</sup> , VENMAR AVS S10 <sup>N</sup> ERV <sup>PLUS</sup>	ALTITUDE, DECO-TOUCH, LITE-TOUCH CONSTRUCTO, SIMPLE-TOUCH CONSTRUCTO OR CONSTRUCTO	DEHUMIDISTAT, 20/40/60-MINUTE LIGHTED PUSH-BUTTON TIMER AND 60-MINUTE CRANK TIMER
VÄNEE 70E+, VÄNEE 70E <sup>N</sup> +	PLATINUM, DECO-TOUCH, LITE-TOUCH BRONZE, SIMPLE-TOUCH BRONZE OR BRONZE	
VENMAR AVS S10 ERV	DECO-TOUCH, LITE-TOUCH CONSTRUCTO OR CONSTRUCTO	
VÄNEE 70E	DECO-TOUCH, LITE-TOUCH BRONZE OR BRONZE	DEHUMIDISTAT, 20-MINUTE LIGHTED PUSH-BUTTON TIMER AND 60-MINUTE CRANK TIMER
VENMAR AVS S10 <sup>C</sup> ERV	LITE-TOUCH CONSTRUCTO OR CONSTRUCTO	
VÄNEE 70E <sup>C</sup>	LITE-TOUCH BRONZE OR BRONZE	

6. This unit must be grounded. The power supply cord has a 3-prong grounding plug for your personal safety. It must be plugged into a mating 3-prong grounding receptacle, grounded in accordance with the national electrical code and local codes and ordinances. Do not remove the ground prong. Do not use an extension cord.
7. Do not install in a cooking area or connect directly to any appliances.
8. Do not use to exhaust hazardous or explosive materials and vapors.
9. When performing installation, servicing or cleaning these units, it is recommended to wear safety glasses and gloves.
10. When applicable local regulation comprise more restrictive installation and/or certification requirements, the aforementioned requirements prevail on those of this document and the installer agrees to conform to these at his own expenses.

### CAUTION

1. To avoid premature clogged filters, turn OFF the unit during construction or renovation.
2. Please read specification label on product for further information and requirements.
3. Be sure to duct air outside – Do not intake/exhaust air into spaces within walls or ceiling or into attics, crawl spaces, or garage.
4. Intended for residential installation only in accordance with the requirements of NFPA 90B (for a unit installed in U.S.A.) or Part 9 of the National Building Code of Canada (for a unit installed in Canada).
5. Do not run any air ducts directly above or closer than 2 ft (0.61 m) to any furnace or its supply plenum, boiler, or other heat producing appliance. If a duct has to be connected to the furnace return plenum, it must be connected not closer than 9' 10" (3 m) from this plenum connection to the furnace.
6. The ductwork is intended to be installed in compliance with all local and national codes that are applicable.
7. When leaving the house for a long period of time (more than two weeks), a responsible person should regularly check if the unit operates adequately.
8. If the ductwork passes through an unconditioned space (e.g.: attic), the unit must operate continuously except when performing maintenance and/or repair. Also, the ambient temperature of the house should never drop below 18°C (65°F).

---

---

# TABLE OF CONTENTS

---

---

1. TYPICAL INSTALLATIONS .....	4-5
1.1 FOR HOUSE .....	4
1.1.1 FULLY DUCTED SYSTEM.....	4
1.1.2 CENTRAL DRAW POINT.....	4
1.1.3 SIMPLIFIED INSTALLATION.....	4
1.2 FOR HIGH-RISE DWELLING .....	5
1.2.1 FULLY DUCTED SYSTEM .....	5
1.2.2 CENTRAL DRAW POINT .....	5
2. INSTALLATION.....	5-12
2.1 INSPECT THE CONTENT OF THE BOX .....	5
2.2 UNIT PREPARATION .....	5
2.3 LOCATING THE UNIT .....	6
2.4 HOW TO HANG THE UNIT .....	6-8
2.5 PLANNING OF THE DUCTWORK .....	8
2.6 INSTALLING THE DUCTWORK AND REGISTERS .....	8-10
2.6.1 FULLY DUCTED SYSTEM.....	8
2.6.2 CENTRAL DRAW POINT.....	9
2.6.3 SIMPLIFIED INSTALLATION.....	10
2.7 CONNECTING THE DUCTS TO THE UNIT.....	11
2.8 INSTALLING 2 EXTERIOR HOODS.....	12
2.9 INSTALLING TANDEM® TRANSITION KIT .....	12
3. CONTROLS.....	13-16
3.1 BOOTING SEQUENCE.....	13
3.1.1 S10 ERVPLUS, S10N ERVPLUS, 70E+ AND 70EN+ UNITS BOOTING SEQUENCE .....	13
3.1.2 S10 ERV, S10c ERV, 70E AND 70Ec UNITS BOOTING SEQUENCE .....	13
3.2 S10 ERVPLUS, S10N ERVPLUS, 70E+ AND 70EN+ UNITS INTEGRATED DEFROST CONTROL.....	14
3.3 S10 ERV, S10c ERV, 70E AND 70Ec UNITS INTEGRATED CONTROL.....	14
3.4 SETTING EXTENDED DEFROST FOR S10 ERV, S10c ERV, 70E AND 70Ec UNITS.....	14
3.5 ELECTRICAL CONNECTION TO WALL CONTROLS .....	15-16
3.5.1 ELECTRICAL CONNECTION TO ALTITUDE AND PLATINUM MAIN WALL CONTROL.....	16
3.5.2 ELECTRICAL CONNECTION TO DECO-TOUCH MAIN WALL CONTROL.....	16
3.5.3 ELECTRICAL CONNECTION TO LITE-TOUCH CONSTRUCTO OR BRONZE, OR SIMPLE-TOUCH CONSTRUCTO OR BRONZE MAIN WALL CONTROLS.....	16
3.5.4 ELECTRICAL CONNECTION TO CONSTRUCTO OR BRONZE MAIN WALL CONTROL .....	16
3.5.5 ELECTRICAL CONNECTION TO OPTIONAL AUXILIARY WALL CONTROLS .....	16
4. ELECTRICAL CONNECTION TO THE FURNACE .....	17
5. SPEED SELECTION .....	17
6. WIRING DIAGRAM .....	18
7. BALANCING THE UNIT .....	19
7.1 WHAT YOU NEED TO BALANCE THE UNIT .....	19
7.2 PRELIMINARY STAGES TO BALANCE THE UNIT .....	19
7.3 BALANCING PROCEDURE.....	19
8. SERVICE PARTS.....	20-21
9. TROUBLESHOOTING .....	22-24

# 1. TYPICAL INSTALLATIONS

Use the following illustrations as guidelines to help you decide on how the unit will be installed.

All the units should be hung from the joists or ceiling using brackets (included with the unit). If desired, an optional chains and spring kit (part no. 61239, sold separately) can be used instead of brackets.

If required, bathroom fans and a range hood can be used to exhaust stale air. Also, for homes with more than one level, we recommend one exhaust register at the highest level.

There are 3 installation methods: Fully ducted, Central Draw Point and Simplified Installation.

NOTE: A standard 3-prong electrical outlet has to be available within 3 feet of the unit.

## 1.1 FOR HOUSE

### 1.1.1 FULLY DUCTED SYSTEM (PRIMARYLY FOR HOMES WITH RADIANT HOT WATER OR ELECTRIC BASEBOARD HEATING)

Stale air coming from the registers located at the highest level of the house is exhausted to the outside. Fresh air from outside is filtered and supplied by the register located in the lowest liveable level.

Homes with more than one level require at least one exhaust register at the highest level.

See figure at right.

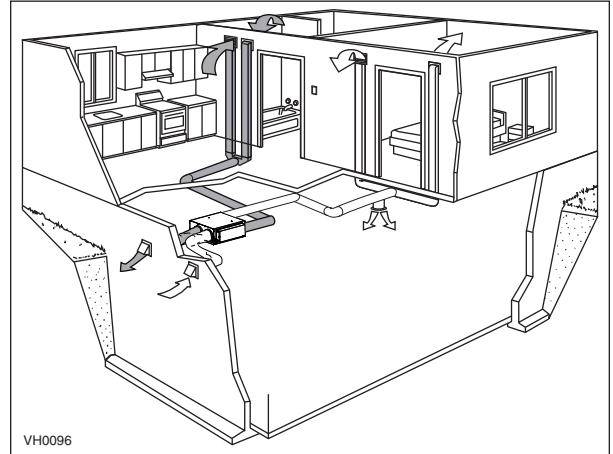

### 1.1.2 CENTRAL DRAW POINT (CONNECTION TO A FORCED AIR SYSTEM)

Stale air coming from the registers located at the highest level of the house is exhausted to the outside. Fresh air from outside is filtered and supplied to the return (plenum) or the supply duct of the forced air unit. See figure at right.

For this type of installation, it is not essential that the forced air system blower runs when the unit is in operation, but we recommend it.

NOTE: Home with multiple forced air systems should have one unit on each system.

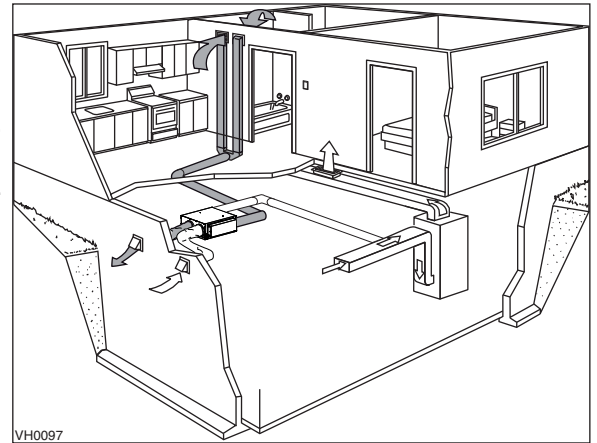

### 1.1.3 SIMPLIFIED INSTALLATION (CONNECTION TO A FORCED AIR SYSTEM)

Stale air is exhausted to the outside. Fresh air from outside is filtered and supplied to the return (plenum) or the supply duct of the forced air unit.

See figure at right.

To avoid cross-contamination and achieve the highest efficiencies, the forced air system blower must always be ON.

NOTE: Home with multiple forced air systems should have one unit on each system.

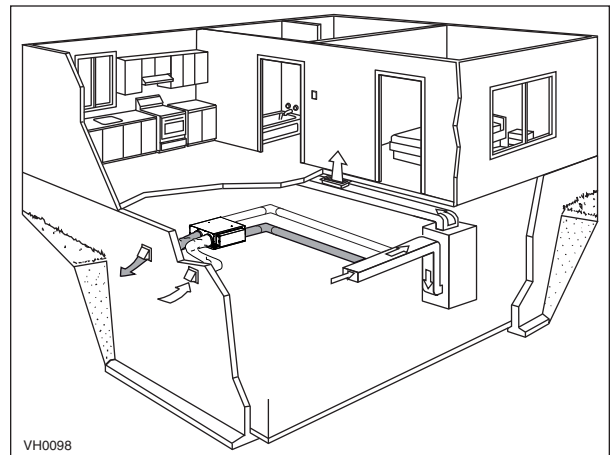

# 1. TYPICAL INSTALLATIONS (CONT'D)

## 1.2 FOR HIGH-RISE DWELLING

### 1.2.1 FULLY DUCTED SYSTEM (PRIMARYLY FOR HOMES WITH RADIANT HOT WATER OR ELECTRIC BASEBOARD HEATING)

Stale air coming from the registers located in bathrooms and kitchen is exhausted to the outside. Fresh air from outside is filtered and supplied by the registers located in bedrooms and living room.

See figure at right.

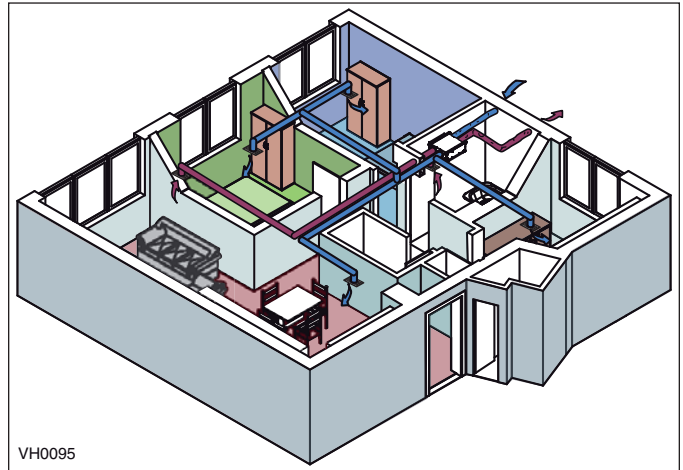

### 1.2.2 CENTRAL DRAW POINT (CONNECTION TO A FAN-COIL SYSTEM)

Stale air coming from the registers located in bathrooms and kitchen is exhausted to the outside. Fresh air from outside is filtered and supplied to the supply duct of the fan-coil system unit. See figure at right.

For this type of installation, it is not essential that the fan-coil system blower runs when the unit is in operation, but we recommend it.

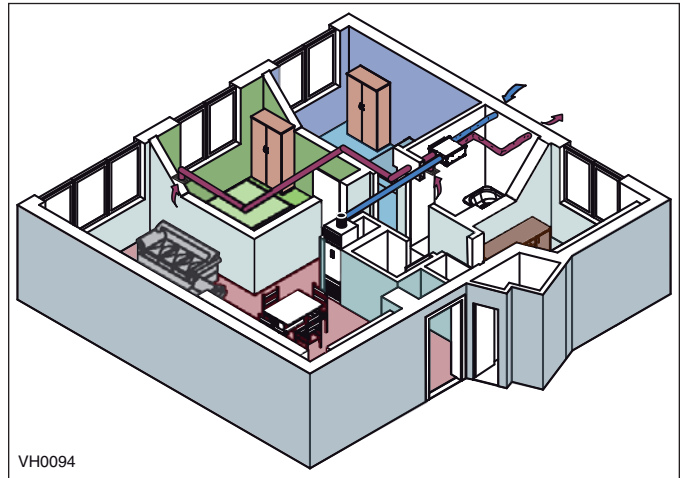

## 2. INSTALLATION

### 2.1 INSPECT THE CONTENTS OF THE BOX

- Inspect the exterior of the unit for shipping damage. Ensure that there is no damage to the door, door hinges, power cord, etc.
- Open the unit door and inspect the interior of the unit for damage. Ensure that energy recovery core, core filters, insulation, dampers, etc. are all intact.

### 2.2 UNIT PREPARATION

All units are equipped with 2 ports having integrated balancing damper (Fresh air to building and Exhaust air to outdoors ports). Before installing the unit, check if these 2 ports are in wide open position. If not, proceed as follow:

- ❶ Loosen the damper lever locking screw.
- ❷ Use the damper lever to open the damper.
- ❸ Lock the damper in position by tightening the locking screw.

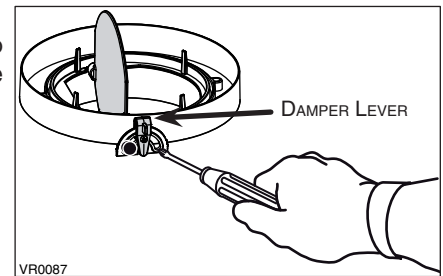

**CAUTION**  
When loosening or tightening the damper lever locking screw, never use an electric screwdriver or drill, use a standard screwdriver.



## 2. INSTALLATION (CONT'D)

### 2.3 LOCATING THE UNIT

Choose an appropriate location for the unit.

- Within an area of the house where **the ambient temperature is kept between 18°C (65°F) and 40°C (104°F)**.
- So as to provide easy access to the interior of the unit, for quarterly and annual maintenance.
- Close to an exterior wall, so as to limit the length of the insulated flexible duct to and from the unit.
- Away from hot chimneys and other fire hazards.
- Allow for a power source within 3 feet (standard 3-prong grounding outlet).

### 2.4 HOW TO HANG THE UNIT

#### ⚠ WARNING

**Never handle the unit using its ports; hold the unit by its sides.**

Hang the unit using 2 included brackets. See below.

#### ⚠ WARNING

**To ensure occupants safety, ensure the brackets are mounted to solid surface (e.g.: concrete ceiling, joists).**

#### CAUTION

**The included screws are for wood joist only; do not use them to secure brackets to concrete ceiling or metal joists.**

- 1 Mount brackets to ceiling or joists. To ease the brackets location, use the template printed on the cardboard filler located in the unit box. See below.

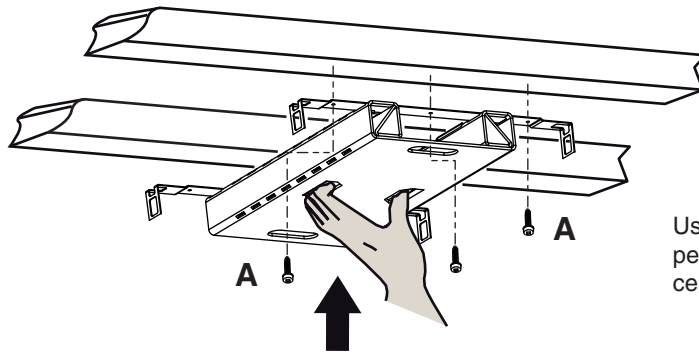
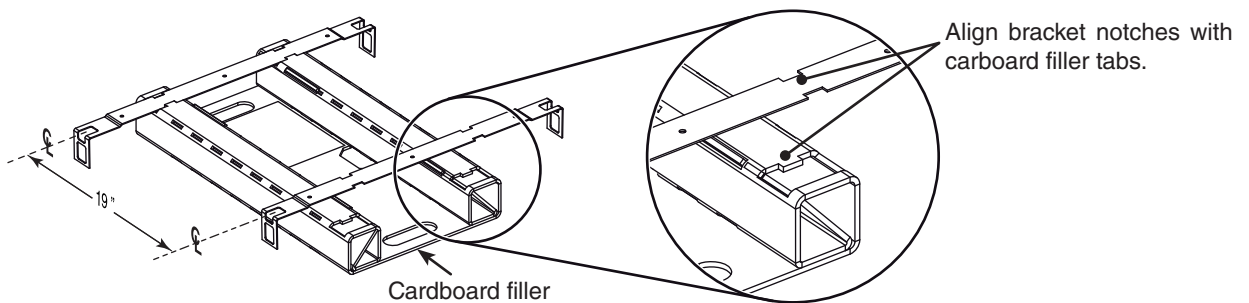

Use at least 2 end screws (A) (or nails) per bracket to secure them to the joists or ceiling; the center one is optional.

VO0259A

## 2. INSTALLATION (CONT'D)

### 2.4 HOW TO HANG THE UNIT (CONT'D)

- 2 Bend 90° integrated hooks (2 places).

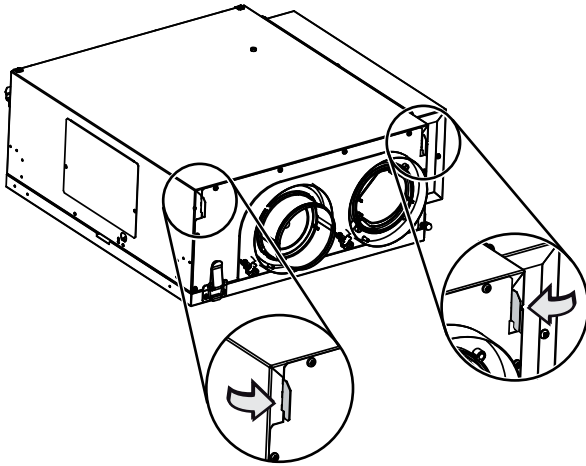

- 3 Hang the hooks onto the brackets.

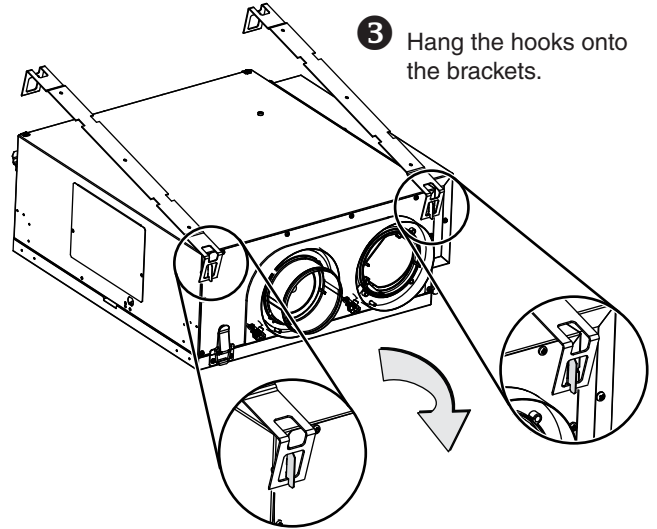

- 4 Clip the other side of unit onto the brackets (2 places).

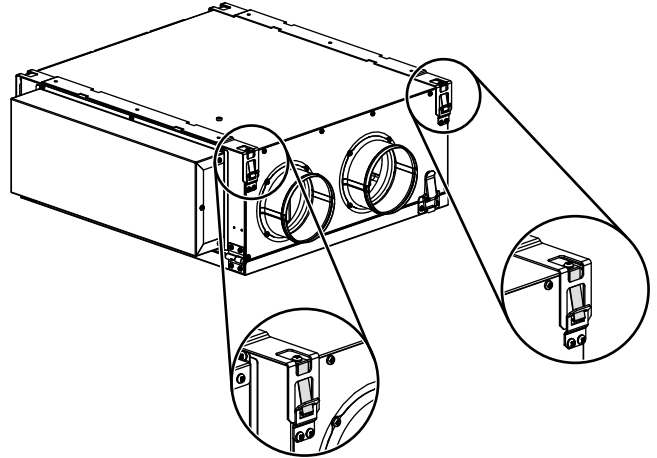
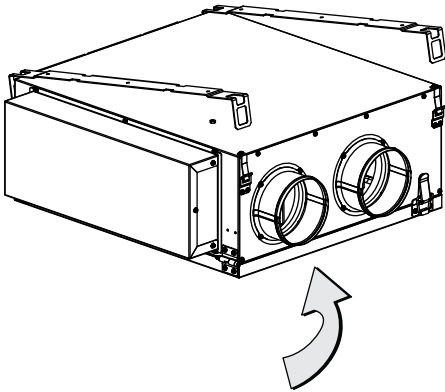

VD0338

### ⚠ WARNING

Ensure the unit is completely held by the brackets before continuing the installation.

NOTE: The unit can also be hung using 4 hooks (shaded part in illustration at right), chains, springs and screws (kit sold separately, part no. 61239).

### CAUTION

Make sure the unit is level.

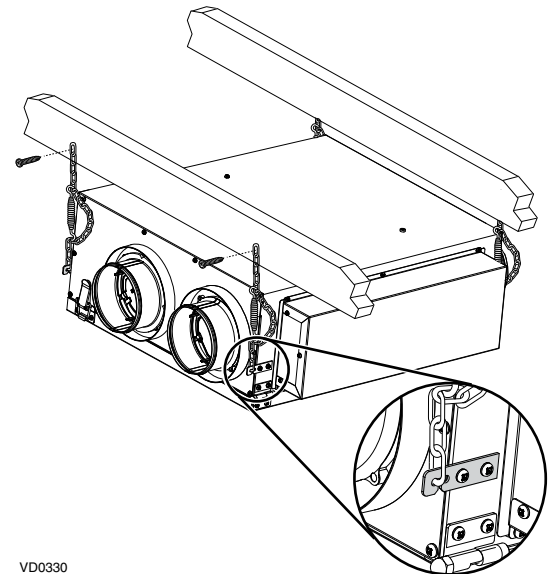

VD0330

## 2. INSTALLATION (CONT'D)

---

### 2.5 PLANNING OF THE DUCTWORK

- Keep it simple. Plan for a minimum of bends and joints.
- Keep the length of insulated ducts to a minimum.
- Do not ventilate crawl spaces or cold rooms. Do not attempt to recover the exhaust air from a dryer or a range hood. This would cause clogging of the filters and recovery module.
- If the house has two floors or more, be sure to plan for at least one exhaust register on the highest lived-in level.

### 2.6 INSTALLING THE DUCTWORK AND REGISTERS

#### **⚠ WARNING**

**Never install a stale air exhaust register in a closed room where a combustion device operates, such as a gas furnace, a gas water heater or a fireplace.**

#### 2.6.1 FULLY DUCTED SYSTEM (AS ILLUSTRATED IN SECTIONS 1.1.1 AND 1.2.1)

##### **Stale air exhaust ductwork:**

- Install the stale air exhaust registers where the contaminants are produced: kitchen, living room, etc. Position the registers as far from the stairway as possible and in such a way that the air circulates in all the lived-in spaces in the house.
- If a register is installed in the kitchen, it must be located at least 4 feet (1.2 m) from the range.
- Install the registers 6 to 12 inches (152 to 305 mm) from the ceiling on an interior wall OR install them in the ceiling.

##### **Fresh air distribution ductwork:**

- Install the fresh air distribution registers in bedrooms, dining rooms, living room and basement.
- Keep in mind that the fresh air registers must be located as far as possible from the stale air registers.
- Install the registers in the ceiling OR 6 to 12 inches (152 to 305 mm) from the ceiling on an interior wall.
- If a register must be floor installed, direct the airflow up the wall.



## 2. INSTALLATION (CONT'D)

### 2.6 INSTALLING THE DUCTWORK AND REGISTERS (CONT'D)

#### 2.6.2 CENTRAL DRAW POINT SYSTEM (AS ILLUSTRATED IN SECTIONS 1.1.2 AND 1.2.2)

##### Stale air exhaust ductwork:

Same as for Fully Ducted System, described on point 2.6.1

##### Fresh air distribution ductwork:

#### ⚠ WARNING

When performing duct connections, always use approved tools and materials. Respect all corresponding laws and safety regulations. Please refer to your local building code.

#### CAUTION

When performing duct connections to the furnace supply duct, this duct must be sized to support the additional airflow produced by the ERV. Also, use a steel duct.

There are 2 methods for connecting the unit to the furnace/air handler:

##### Method 1: Supply side connection (All units)

- Cut an opening into the furnace supply duct at least 18 inches (0.5 m) from the furnace/air handler.
- Connect this opening to the **Fresh air to building** port of the ERV (use **steel duct**, see figure at right).
- Make sure the ERV duct forms an elbow inside the furnace/air handler ductwork.
- If desired, interlock (synchronize) the furnace/air handler blower operation (see Section 4).

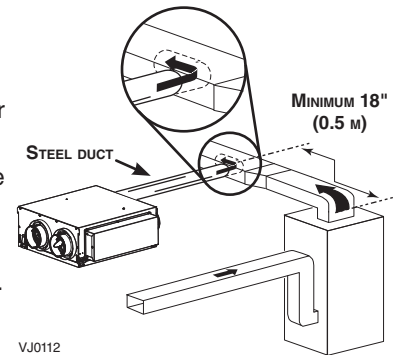

##### Method 2: Return side connection (exclusively for AVS S10 ERVplus, S10n ERVplus, 70E+ and 70EN+ units only)

- Cut an opening into the furnace return duct not less than 10 feet (3.1 m) from the furnace/air handler (**A+B**).
- Connect this opening to the **Fresh air to building** port of the ERV (see figure at right).

NOTE: For Method 2, it is not essential that the furnace/air handler runs when the unit is in operation, but we recommend it. If desired, interlock (synchronize) the furnace/air handler blower operation (see Section 4).

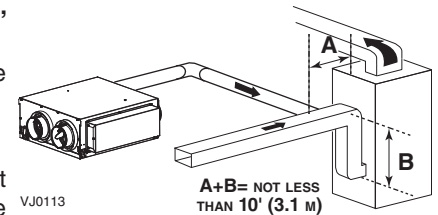

## 2. INSTALLATION (CONT'D)

### 2.6 INSTALLING THE DUCTWORK AND REGISTERS (CONT'D)

#### 2.6.3 SIMPLIFIED INSTALLATION (AS ILLUSTRATED IN SECTION 1.1.3)

#### ⚠ WARNING

When performing duct connections, always use approved tools and materials. Respect all corresponding laws and safety regulations. Please refer to your local building code.

#### CAUTION

When performing duct connections to the furnace supply duct, this duct must be sized to support the additional airflow produced by the ERV. Also, use a steel duct. For a Return-Return installation, the furnace blower must be in operation when the ERV is in operation.

There are 2 methods for connecting the unit to the furnace/air handler:

#### Method 1: Supply-return connection (All units)

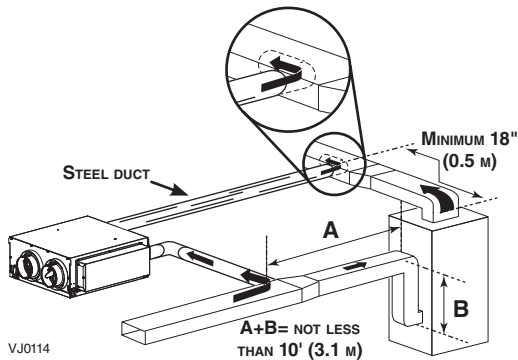

#### Method 2: Return-return (exclusively for AVS S10 ERVplus, AVS S10n ERVplus, 70E+ and 70EN+ units)

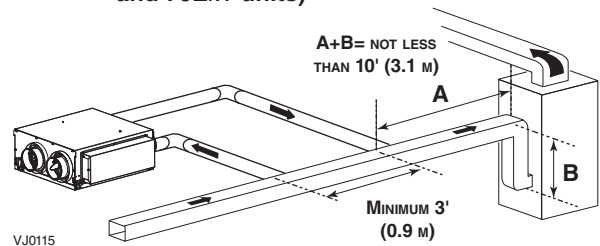

#### Stale air intake:

- Cut an opening into the furnace/air handler return duct not less than 10 feet (3.1 m) from the furnace/air handler (**A+B**).
- Connect this opening to the **Exhaust air from building** port of the ERV.

#### Fresh air distribution:

- Same instructions as for Method 1 or Method 2, Section 2.6.2.

For Method 2 (Return-return), make sure there is a distance of at least 3 feet (0.9 m) between the 2 connections to the furnace/air handler.

NOTE: For Method 1, it is not essential to synchronize the furnace blower operation with the unit operation, but we recommend it.

#### CAUTION

If using Method 2, make sure the furnace/air handler blower operation is synchronized with the unit operation! See Section 4.

## 2. INSTALLATION (CONT'D)

### 2.7 CONNECTING THE DUCTS TO THE UNIT

NOTE: All units ports were created to be connected to ducts having a minimum of 5" diameter, but if need be, they can be connected to bigger sized ducts by using an appropriate transition (e.g.: 5" diameter to 6" diameter transition).

#### Insulated flexible ducts:

#### CAUTION

Make sure the balancing dampers are set to wide open position before connecting the ducts to the ports. Also, the ductwork connecting Fresh air to building and Exhaust air to outdoors ports with exterior hood(s) must be made of insulated ducts, all way long.

All units have both Fresh air to building and Exhaust air to outdoors ports equipped with integrated balancing damper. Prior to install the insulated flexible ducts on, ensure these both ports have their dampers set to wide open position (See Section 2.2)

#### CAUTION

If ducts have to go through an unconditioned space (e.g.: attic), always use insulated ducts.

Use the following procedure for connecting the insulated flexible ducts to the port of the unit (*Exhaust air to outdoors* and *Fresh air from outdoors* ports).

- 1 Pull back the insulation to expose the flexible duct.
- 2 Attach the flexible duct to the port using tie wrap.
- 3 Pull the insulation over the joint and tuck in between the inner and outer rings of the double collar, then pull down the vapor barrier (shaded part in illustrations below) over the insulation and tuck in between the inner and outer rings.
- 4 Apply duct tape to the joint (outer ring and vapor barrier) making an airtight seal. Avoid compressing the insulation when pulling the tape tightly around the joint. Compressed insulation loses its R value and causes water dripping due to condensation on the exterior surface of the duct.

#### CAUTION

Make sure the vapor barrier on the insulated ducts does not tear during installation to avoid condensation within the ducts.

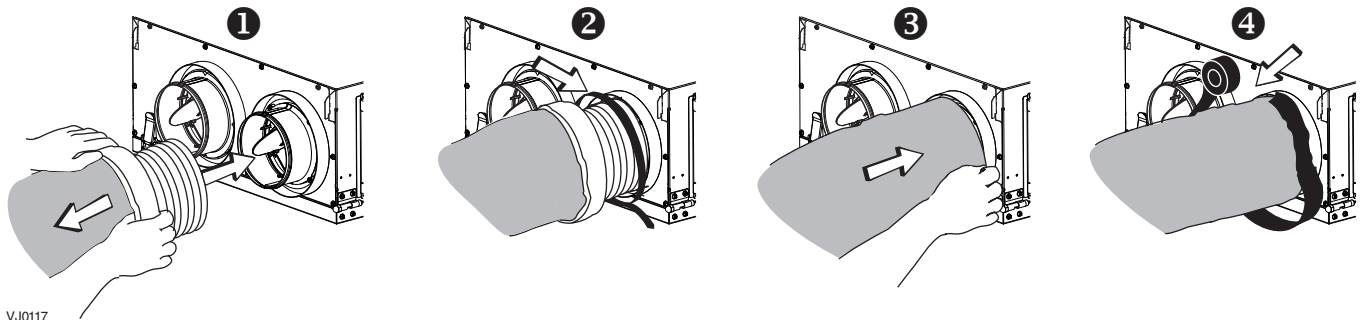

#### Rigid ducts:

#### CAUTION

Do not use screws to connect the rigid ducts to the ports.

Use a small length (6" length) of flexible duct to connect the rigid duct to the ports in order to avoid vibration transmissions. Use tie-wraps to perform connections, then seal with duct tape.

## 2. INSTALLATION (CONT'D)

### 2.8 INSTALLING 2 EXTERIOR HOODS

Choose an appropriate location to install the exterior hoods:

- There must be a minimum distance of 6' (1.8 m) between the hoods to avoid cross-contamination
- There must be a minimum distance of 18" (457 mm) from the ground

#### ⚠ WARNING

Make sure the intake hood is at least 6 feet (1.8 m) away from any of the following:

- Dryer exhaust, high efficiency furnace vent, central vacuum vent
- Gas meter exhaust, gas barbecue-grill
- Any exhaust from a combustion source
- Garbage bin and any other source of contamination

Refer to figure below for connecting insulated ducts to the exterior hoods. An "Anti-gust intake hood" should be installed in regions where a lot of snow is expected to fall.

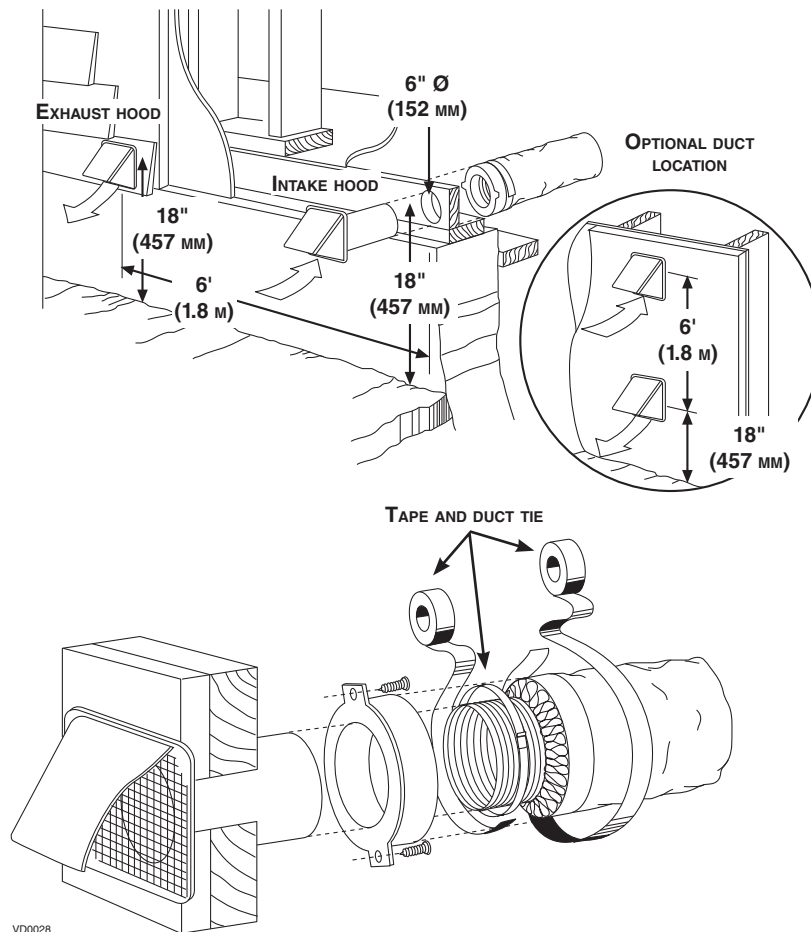

### 2.9 INSTALLING TANDEM® TRANSITION\* KIT

If desired, a Tandem transition kit can be used instead of 2 exterior hoods.

The joist opening needed to install the Tandem® transition must be 9¾" minimum. The maximum height of the Tandem transition is 8¾".

To connect the insulated flexible ducts to the Tandem transition (*Exhaust air to outdoors* and *Fresh air from outdoors*), follow the instructions included with the Tandem transition kit (part no. 14690).

\*Patented.

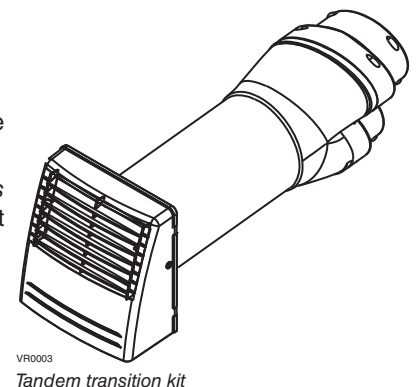

### 3. CONTROLS

The S10 ERVplus, S10n ERVplus, 70E+ and 70EN+ units are equipped with an integrated defrost control while the S10 ERV, S10c ERV, 70E and 70Ec units have an integrated control. In both cases, those electronic devices are located under the unit, in front of the electrical compartment. Refer to the figure at right for steps 3.1 up to 3.4. Plug the unit.

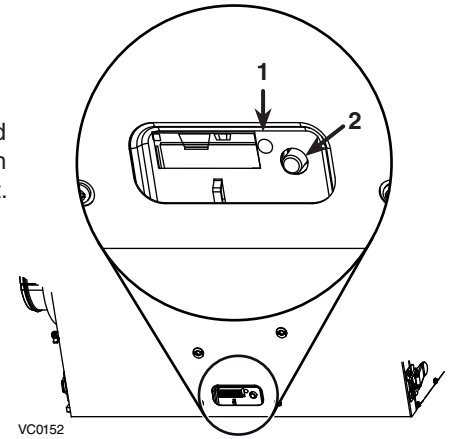

#### 3.1 BOOTING SEQUENCE

The unit booting sequence is similar to a personal computer boot sequence. Each time the unit is plugged after being unplugged, or after a power failure, the unit will perform a booting sequence before starting to operate.

3.1.1 S10 ERVPLUS, S10n ERVPLUS, 70E+ AND 70EN+ UNITS BOOTING SEQUENCE	3.1.2 S10 ERV, S10c ERV, 70E AND 70Ec UNITS BOOTING SEQUENCE
<p>During the booting sequence, the integrated defrost control LED (1 in above illustration) will be OFF for 3 seconds, and then will turn RED for the rest of the booting sequence (approximately 15 seconds). During this RED light phase, the unit is checking and resetting the motorized damper position. Once the motorized damper position completely set, the booting sequence is done; the color of the LED will show on which defrost cycle the unit is set.</p> <p>NOTE: No command will be taken until the unit is fully booted.</p>	<p>During the booting sequence, the integrated control LED (1 in above illustration) will light up and remain GREEN or AMBER for 3 seconds, and will then shut off*; the booting sequence is done.</p> <p>* or will light up in the color of the previous mode to show the unit resumed to it, if the unit is controlled by its integrated control.</p> <p>NOTE: No command will be taken until the unit is fully booted.</p>

If a problem occurs during the unit operation, or if the unit turns in Protection Mode, its LED (1) will blink. The color and the blinking pattern depend on the type of error detected, or if the unit is in Protection Mode. Refer to the sticker on the unit and Section 9 Troubleshooting on page 22 for further details.

### 3. CONTROLS (CONT'D)

#### 3.2 S10 ERVPLUS, S10N ERVPLUS, 70E+ AND 70EN+ UNITS INTEGRATED DEFROST CONTROL

After the booting sequence is done, the LED (1) will light and stay lit to show in which defrost cycle the unit is set. Use the push button (2) to change the defrost cycle of the unit (see table at right).

LED COLOR	DEFROST CYCLE
GREEN	STANDARD
RED	PLUS
AMBER	DISCRETION

NOTE: There is a 15-minute delay for the new defrost cycle choice to be kept in memory; if a power failure occurs during this time delay, when the power returns, the unit resume to its previous setting.

According to your needs, there are 3 defrost cycles available:

**STANDARD:** This is the factory set defrost cycle. Being the most energy recovery efficient defrost cycle available on this unit, STANDARD is used to achieve HVI and ENERGY STAR® listed performance. When needed, the unit will perform defrost cycle on high speed.

**PLUS:** This mode has been created for people who live in cold region (outside temperature -27°C [-17°F] and lower). This setting makes the unit perform defrost cycle on high speed for a longer period of time.

**DISCRETION:** When needed, the defrost cycle will be performed on the same speed than the unit ventilation speed. This means that if the unit is set on high speed, the defrost cycle will be done on high speed, but if the unit is set on low speed, the defrost cycle will be done on low speed.

#### 3.3 S10 ERV, S10c ERV, 70E AND 70Ec UNITS INTEGRATED CONTROL

Use the push button (2) to control the unit. The LED (1) will then shows on which mode the unit is in. Refer to table at right.

**NOTE: When using main control, the integrated control must be turned off.**

LED COLOR	RESULTS
AMBER	UNIT IS ON LOW SPEED
GREEN	UNIT IS ON HIGH SPEED
No LIGHT	UNIT IS OFF OR CONTROLLED BY A MAIN CONTROL

#### 3.4 SETTING EXTENDED DEFROST FOR S10 ERV, S10c ERV, 70E AND 70Ec UNITS

These units are factory set to normal defrost. In cold region (outside temperature -27°C [-17°F] and lower), it may be necessary to setup extended defrost. During the first 3 seconds of booting sequence, the integrated control LED shows the current defrost mode (refer to table at right).

LED COLOR	DEFROST MODE
GREEN	NORMAL
AMBER	EXTENDED*

Within the first 3 seconds of booting sequence, press on push button until the LED starts to blink, then release the push button; the LED will blink AMBER 5 times. After that, the LED will shut off, then turn RED (the unit returns in its booting sequence).

\*Due to their unique design, the S10c ERV and 70Ec models are programmed to defrost on a regular basis, no matter the outdoor temperature, only when set in extended defrost.

### 3. CONTROLS (CONT'D)

#### 3.5 ELECTRICAL CONNECTION TO WALL CONTROLS

Both S10 ERVplus, S10n ERVplus, 70E+ and 70EN+ units must be controlled by a main control. For more convenience, S10 ERV, S10c ERV, 70E and 70Ec units can also be controlled using an optional main control.

NOTES: 1. The integrated control must be turned OFF on S10 ERV, S10c ERV, 70E and 70Ec units to use an optional main control.

2. If an optional auxiliary control is used, if activated, this auxiliary control will override the optional main control operation.

#### ⚠ WARNING

**Always disconnect the unit before making any connections. Failure in disconnecting power could result in electric shock or damage of the wall control or electronic module inside the unit.**

#### CAUTION

**Never install more than one main wall control per unit. Make sure that the wires do not short-circuit between themselves or by touching any other components on the wall control. Avoid poor wiring connections. To reduce electrical interference (noise) potential, do not run wall control wiring next to control contactors or near light dimming circuits, electrical motors, dwelling/building power or lighting wiring, or power distribution panel.**

Open the unit door. Insert the terminal connector (included in the installation kit) under the unit, on the electrical compartment front face. Use this terminal connector to perform the electrical connection for main and optional wall controls, then secure the cable(s) with a tie wrap (see illustration at right).

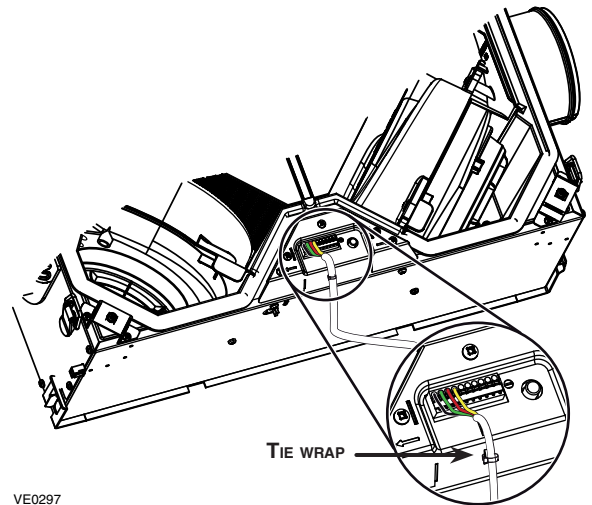

Check if all wires are correctly inserted in their corresponding holes in the terminal block. (A wire is correctly inserted when its orange receptacle is lower than another one without wire. On illustration at right, wire **A** is correctly inserted, but not wire **B**.) Splice back the end of the cable to access the 4 wires. Strip the end of each wire. Connect each wire to its corresponding terminal: YELLOW wire to "Y"; RED wire to "R"; GREEN wire to "G" and BLACK wire to "B". Connect the auxiliary control cable, if installed (not shown).

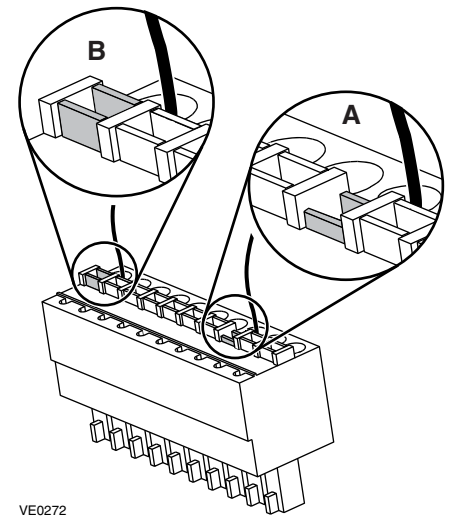

### 3. CONTROLS (CONT'D)

#### 3.5 ELECTRICAL CONNECTION TO WALL CONTROLS (CONT'D)

##### 3.5.1 ELECTRICAL CONNECTION TO ALTITUDE (AVS S10 ERVPLUS AND AVS S10N ERVPLUS UNITS ONLY) OR PLATINUM (70E+ AND 70EN+ UNITS ONLY) MAIN WALL CONTROL

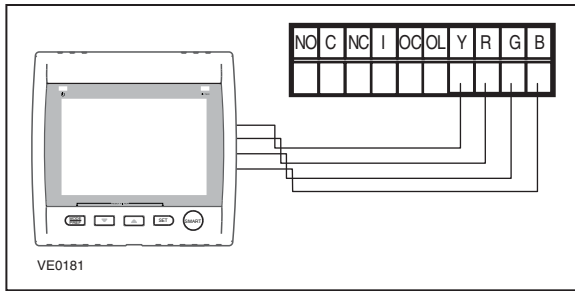

##### 3.5.2 ELECTRICAL CONNECTION TO DECO-TOUCH MAIN WALL CONTROL (AVS S10 ERVPLUS, AVS S10N ERVPLUS, AVS S10 ERV, 70E+, 70EN+ AND 70E UNITS ONLY)

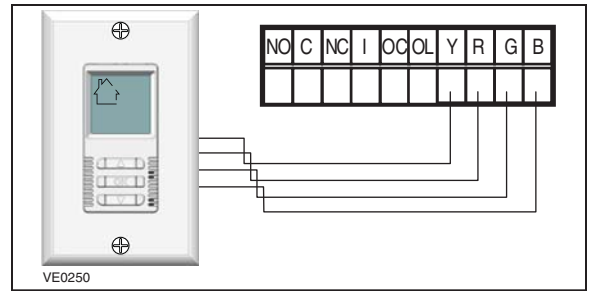

##### 3.5.3 ELECTRICAL CONNECTION TO LITE-TOUCH CONSTRUCTO OR BRONZE, OR SIMPLE-TOUCH CONSTRUCTO OR BRONZE MAIN WALL CONTROL (ALL UNITS)

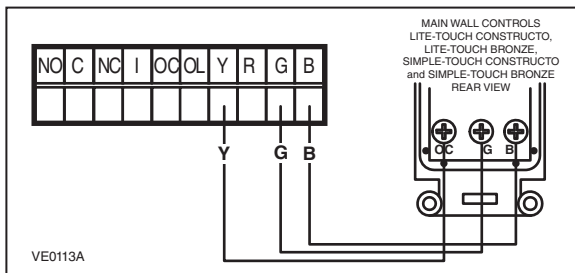

##### 3.5.4 ELECTRICAL CONNECTION TO CONSTRUCTO OR BRONZE MAIN WALL CONTROL (ALL UNITS)

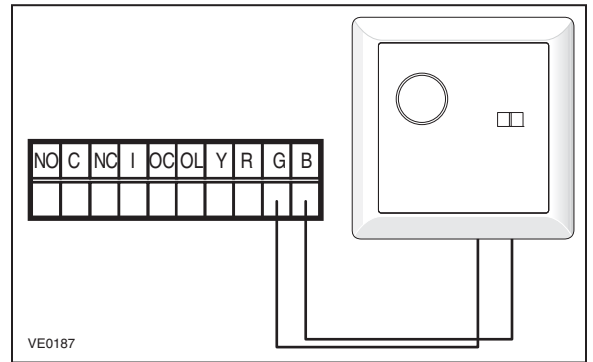

##### 3.5.5 ELECTRICAL CONNECTION TO OPTIONAL AUXILIARY WALL CONTROLS

NOTE: If an optional auxiliary wall control is activated and then, the Dehumidistat is being activated, this one will override the auxiliary wall control commands.

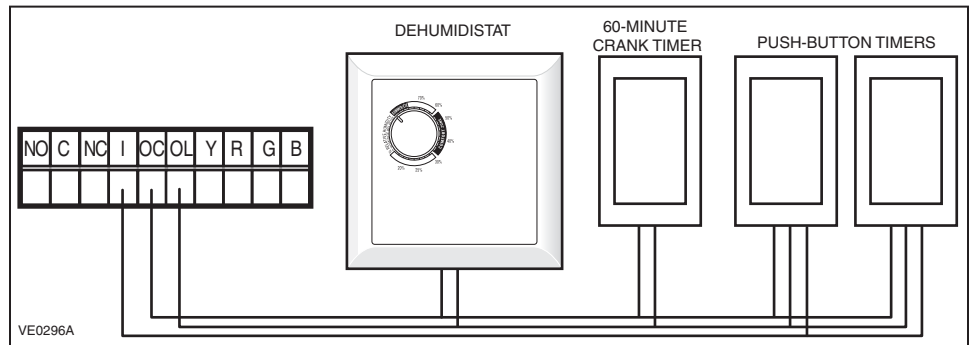

Once the wall control(s) connections have been made and checked, close the unit door.

NOTE: For information about the operation of the wall controls, refer to the user guide.



## 4. ELECTRICAL CONNECTION TO THE FURNACE

### ⚠ WARNING

Never connect a 120-volt AC circuit to the terminals of the furnace interlock (standard wiring). Only use the low voltage class 2 circuit of the furnace blower control.

#### For a furnace connected to a cooling system:

On some older thermostats, energizing the “R” and “G” terminals at the furnace has the effect of energizing “Y” at the thermostat and thereby turning on the cooling system. If you identify this type of thermostat, you must use the ALTERNATE FURNACE INTERLOCK WIRING.

STANDARD FURNACE INTERLOCK WIRING

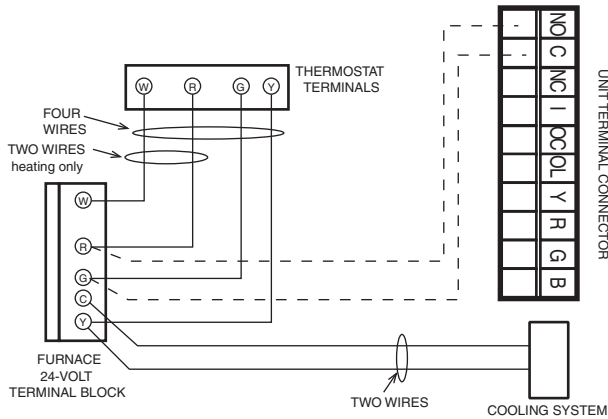

VE0108A

ALTERNATE FURNACE INTERLOCK WIRING

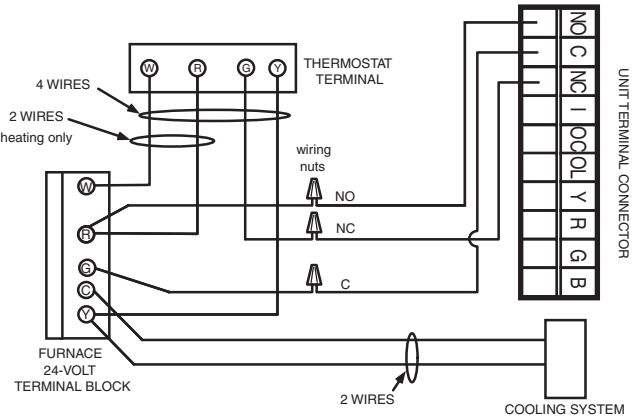

## 5. SPEED SELECTION

The factory set high speed value for these units is 100 CFM, and low speed value is approximately 50 CFM. To change these values, the transformer wire taps connections must be changed (see table and illustration below).

	Speed	Connection
High Speed	100 CFM	BL-BL
	85 CFM	BN-BL
Low Speed	65 CFM	GY-R
	50 CFM	R-R

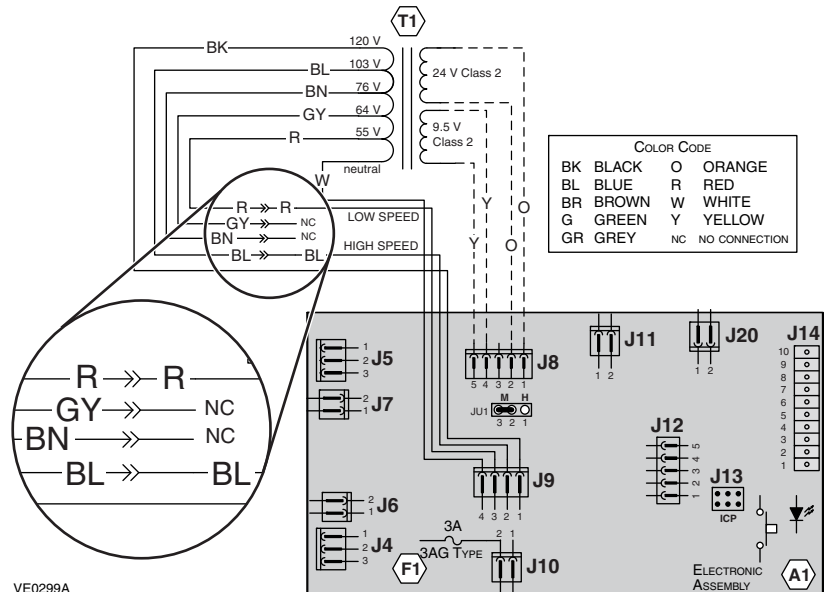

VE0299A

# 6. WIRING DIAGRAM

## ⚠ WARNING

- Risk of electric shocks. Before performing any maintenance or servicing, always disconnect the unit from its power source.
- This product is equipped with an overload protection (fuse). A blown fuse indicates an overload or a short-circuit situation. If the fuse blows, unplug the product and check the polarity and voltage output from the outlet. Replace the fuse as per the servicing instructions (refer to wiring diagram for proper fuse rating) and verify the product. If the replaced fuse blows, it may be a short-circuit and the product must be discarded or returned to an authorized service center for examination and/or repair.

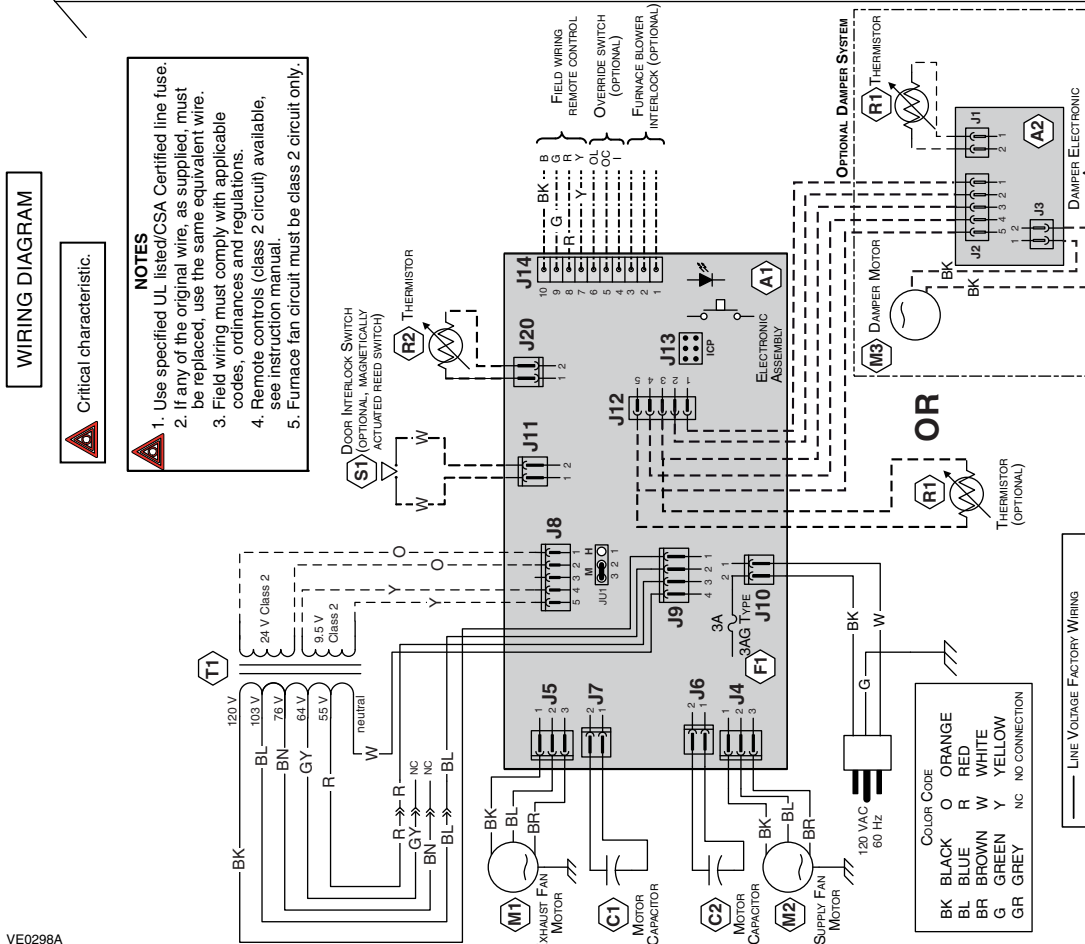
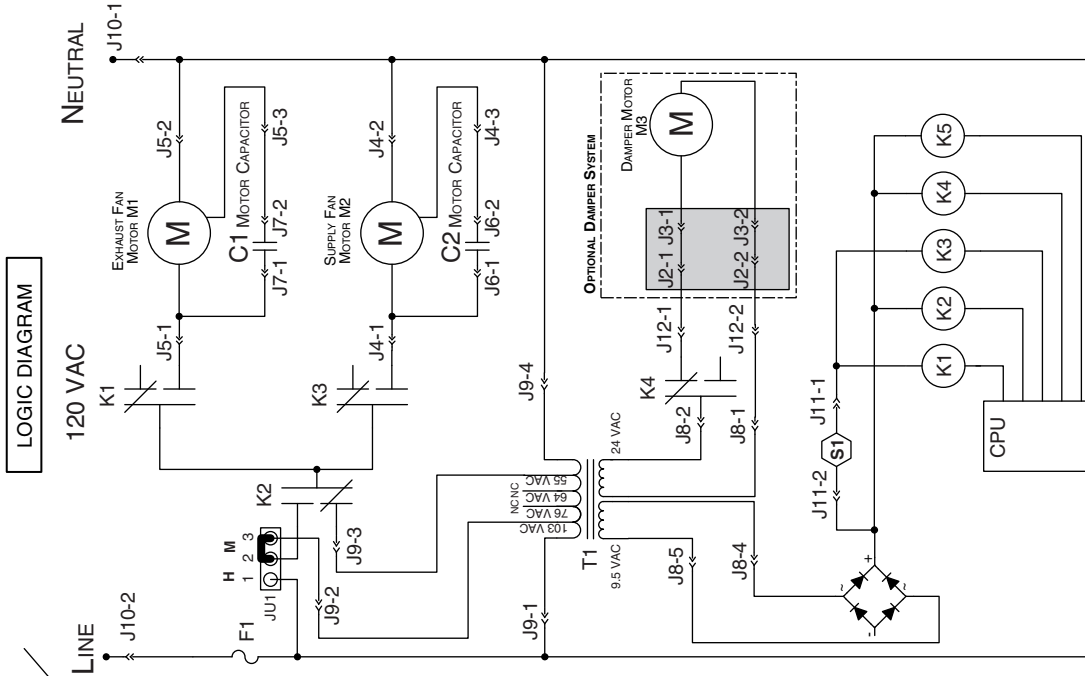

VE0298A

## 7. BALANCING THE UNIT

### 7.1 WHAT YOU NEED TO BALANCE THE UNIT

- A magnehelic gauge capable of measuring 0 to 0.5 inch of water (0 to 125 Pa) and 2 plastic tubes.
- The balancing chart located on the unit door.

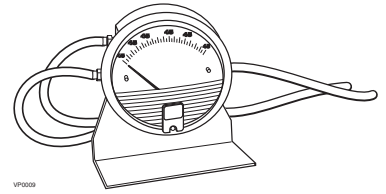

### 7.2 PRELIMINARY STAGES TO BALANCE THE UNIT

- Seal all the unit ductwork with tape. Close all windows and doors.
- Turn off all exhaust devices such as range hood, dryer and bathroom fans.
- Make sure the integrated balancing dampers are fully open. Both are located on the Exhaust air to outside port and on Fresh air from outside port (see step 2.2).
- Make sure all filters are clean (if it is not the first time you balance the unit).

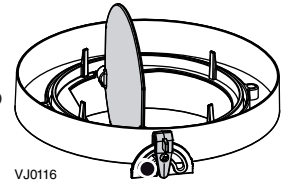

#### **Make sure the unit is not running in defrost mode while balancing.**

When the outdoor temperature is below 0°C/32°F, the defrost mode can be activated. During defrost cycle, it is not possible to balance the unit since there is no flow in one direction.

To cancel the defrost cycle, use the auxiliary control or jump OC-OL on unit terminal block; this will set the unit on high speed ventilation without defrost for the next 20 minutes. Once the 20 minutes of high speed ventilation is completed, the unit will perform an extended defrost. If installed, do not forget to remove the jumper between OL and OC on terminal block.

Another way to avoid the defrost cycle is to wait 10 minutes after plugging the unit in; this procedure ensures that the unit is not in a defrost cycle.

NOTE: Most of vänEE and Venmar units start in defrost mode within the first minute of operation.

### 7.3 BALANCING PROCEDURE

#### 1. Set the unit to high speed.

Make sure that the furnace/air handler blower is ON if the installation is in any way connected to the ductwork of the cold air return. If not, leave furnace/air handler blower OFF.

#### 2. Place the magnehelic gauge on a level surface and adjust it to zero.

#### 3. Connect tubing from gauge to exhaust air flow pressure taps and fresh airflow pressure taps (see diagram at right).

Be sure to connect the tubes to their appropriate high/low fittings. If the gauge drops below zero, reverse the tubing connections.

#### 4. Measure both flows; adjust higher flow to equal the lower one, using balancing damper lever.

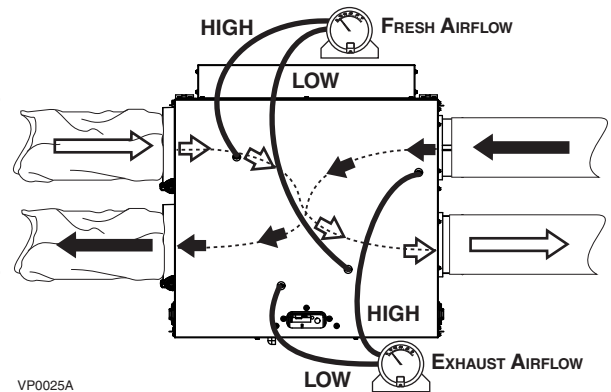

#### **CAUTION**

When loosening or tightening the damper lever locking screw, never use an electric screwdriver or drill, use a standard screwdriver.



#### **CAUTION**

Make sure to turn the damper lever to the right direction (opposite to its stopper, see illustration at right). Securing the lever in wrong position may cause freezing into the unit.

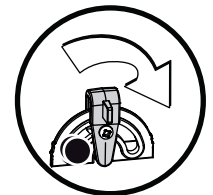
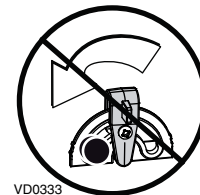

5. Secure both damper levers in place using their locking screw, then shut all the pressure taps with the small plastic plugs included in the hardware kit.
6. Write the required air flow information on a label and stick it near the unit for future reference (date, maximum speed air flows, your name, phone number and business address).

NOTE: The unit is considered balanced even if there is a difference of  $\pm 10$  cfm (or  $\pm 5$  l/s or 17 m<sup>3</sup>/h) between the two air flows.

## 8. SERVICE PARTS

### REPLACEMENT PARTS AND REPAIR

In order to ensure your ventilation unit remains in good working condition, you must use the manufacturer genuine replacement parts only. The manufacturer genuine replacement parts are specially designed for each unit and are manufactured to comply with all the applicable certification standards and maintain a high standard of safety. Any third party replacement part used may cause serious damage and drastically reduce the performance level of your unit, which will result in premature failing. Also, the manufacturer recommends to contact a certified service depot for all replacement parts and repairs.

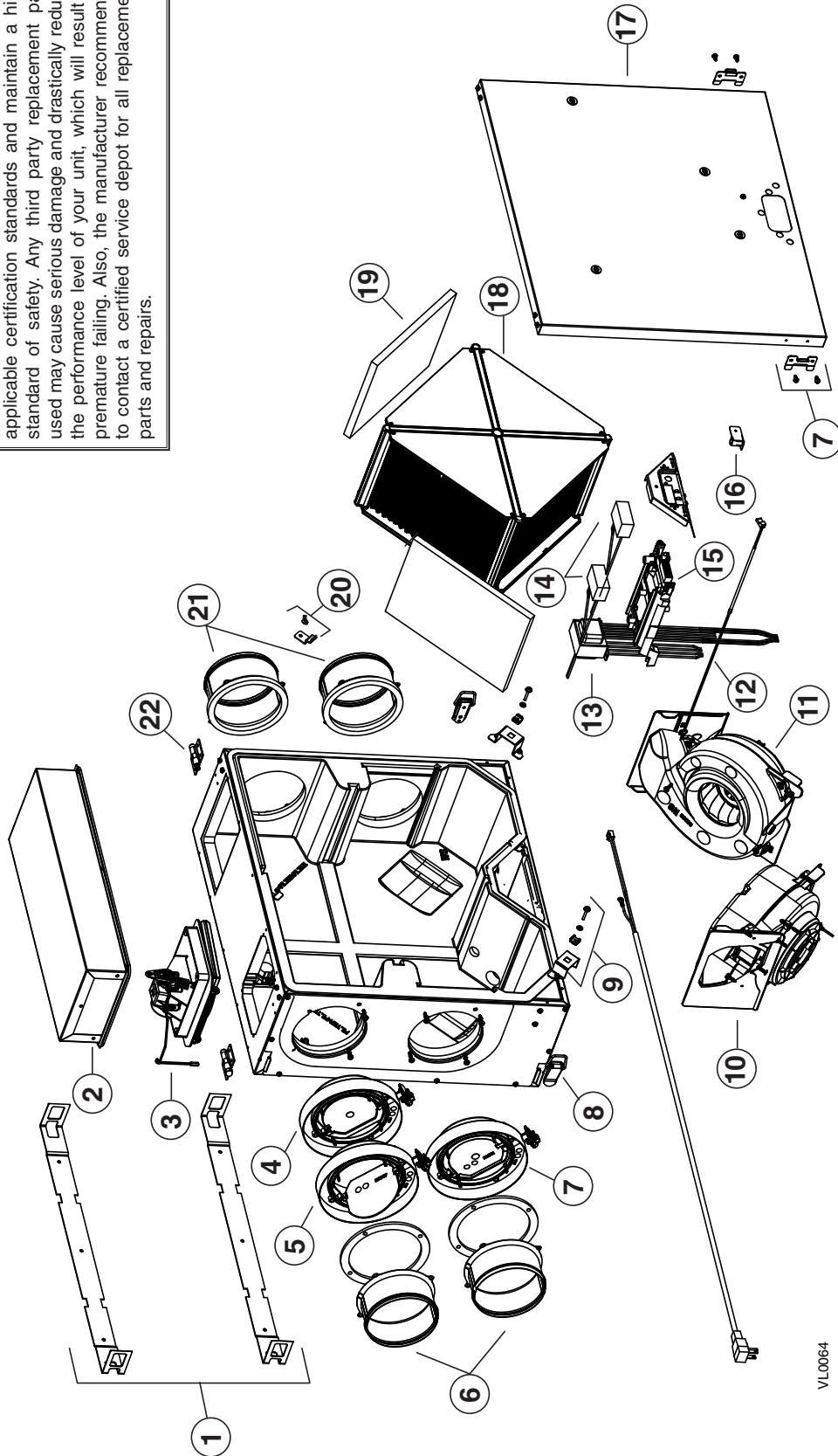

VL0064

8. SERVICE PARTS (CONT'D)

No.	DESCRIPTION	PART No.	S10 ERV	S10 ERVplus	S10n ERVplus	S10c ERV	70E	70E+	70EN+	70Ec
1	INSTALLATION BRACKETS KIT (2)	61240	1	1	1	1	1	1	1	1
2	RECIRCULATION CHANNEL KIT	61213		1				1	1	
3	DAMPER SYSTEM KIT	61214		1				1	1	
4	BALANCING PORT KIT	61216		1				1	1	
5	BALANCING AND BACKDRAFT DAMPER PORT KIT	61219	1			1	1			1
6	5" METAL PORT KIT FOR COLD SIDE	61236	2	2	2	2	2	2	2	2
7	ADJUSTABLE PORT KIT	61215	1	1	1	1	1	1	1	1
8	DOOR METAL KEEPERS AND LATCHES KIT	61218	1	1	1	1	1	1	1	1
9	DOOR BRACKET KIT	61220				1				1
10	COLD SIDE BLOWER KIT (INCL. 1 CAPACITOR)	61235	1	1	1	1	1	1	1	1
11	WARM SIDE BLOWER KIT (INCL. 1 CAPACITOR AND ITEM 12)	61234	1	1	1	1	1	1	1	1
12	WARM SIDE THERMISTOR	61233	1	1	1	1	1	1	1	1
13	TRANSFORMER KIT	61232	1	1	1	1	1	1	1	1
14	CAPACITORS 5 µF (2)	16042	1	1	1	1	1	1	1	1
		61229		1				1		
15	ELECTRONIC BOARD KIT	61230	1				1			1
		61231				1				
		62970			1				1	
16	MAGNET WITH BRACKET KIT	61241	1	1	1		1	1	1	
		61224		1						
		61225						1		
17	DOOR ASSEMBLY	61226				1				1
		61227	1				1			
		62971			1					
		62972							1	
18	FILTER KIT (2)	21029	1	1	1	1	1	1	1	1
	OPTIONAL MERV 7 FILTERS (2)	21030	1	1	1	1	1	1	1	1
19	ERV CORE	61223	1	1	1	1	1	1	1	1
20	CORE LOCKING DEVICE KIT	61237	1	1	1	1	1	1	1	1
21	5" METAL PORT KIT FOR WARM SIDE	61217	2	2	2	2	2	2	2	2
22	DOOR METAL HINGES KIT (2)	61228	2	2	2	2	2	2	2	2
*	TERMINAL CONNECTOR	16416	1	1	1	1	1	1	1	1
*	COLD SIDE THERMISTOR KIT	61221	1				1			
*	OPTIONAL HARDWARE KIT	61239	1	1	1	1	1	1	1	1

\* Not shown.

## 9. TROUBLESHOOTING

If the unit does not work properly, reset the unit by unplugging it for one minute and then replug it. If it still not working properly, refer to table below.

If the LED of the unit is flashing, this means the unit sensors have detected a problem. See the table below to know where the problem occurs on the unit.			
LED SIGNAL	ERROR TYPE	ACTION	UNIT STATUS
LED flashes GREEN (double blink every 2 seconds).	Outside thermistor error.	<ul style="list-style-type: none"> <li>Ensure J12 connector is properly connected and its wires are not damaged. If they are correct:</li> <li><b>For S10 ERVplus, S10n ERVplus, 70E+ and 70EN+ units:</b> replace the damper assembly.</li> <li><b>All other units:</b> replace the fresh air from outside thermistor.</li> </ul>	Unit works but will defrost frequently.
LED flashes GREEN (2 blinks per second; faster blink).	Building side thermistor error.	<ul style="list-style-type: none"> <li>Ensure J20 connector is properly connected and its wires are not damaged. If they are correct:</li> <li>Replace the thermistor in the warm side blower.</li> </ul>	Unit does not work.
LED flashes AMBER (S10 ERVplus, S10n ERVplus, 70E+ and 70EN+ units only).	Damper system error.	<ul style="list-style-type: none"> <li>Go to point 7 in next table.</li> </ul>	Unit does not work.
LED flashes RED (one blink every 2 seconds).	Cold side motor error, open door or magnetic switch bad contact.	<p><b>For S10 ERVplus, S10n ERVplus, S10 ERV, 70E+, 70EN+ and 70E units:</b></p> <ul style="list-style-type: none"> <li>Check if the unit door is properly closed, then push once on integrated push button to restart unit.</li> <li>Check for the door magnet to be properly seated onto the door. If not, correct the situation, close the door and push once on the integrated push button to restart unit.</li> <li>Ensure J11 connector is properly connected and its wires are not damaged. If not, correct the situation, close the door and push once on the integrated push button to restart unit.</li> </ul> <p><b>For S10c ERV and 70Ec units:</b></p> <ul style="list-style-type: none"> <li>Ensure jumper on J11 connector is properly installed. If not, correct the situation, close the door and push once on the integrated push button to restart unit.</li> </ul> <p><b>For all units:</b></p> <ul style="list-style-type: none"> <li>Using a flat blade screwdriver, jump J11 while pushing once on push button at the same time. If the LED is still flashing, go to point 8 in next table for motor diagnosis.</li> </ul>	Unit does not work.
LED flashes RED (2 blinks per second; faster blink). <b>For all units except S10n ERVplus and 70EN+.</b>	Unit is on protection mode or is in error because it has been in protection mode for an abnormal time.	<ul style="list-style-type: none"> <li>If outside temperature is colder than -25°C, it could be normal for the unit to enter in protection mode.</li> <li>To see if the unit is in error, wait 5 minutes, unplug the unit, wait 1 minute and plug it back. Wait for the booting sequence to be done, then see if it still shows this error. If yes, press and hold the push button during 7 seconds to reset this error. Another LED signal can happen; refer to the appropriate LED color code and blinks. If no, go to point 9 in next table.</li> </ul>	Unit exhaust air without entering fresh air for a 2-hour period, then resume to its previous operation mode and stops flashing RED. If LED continues to flash RED when back to previous mode, the unit is in error. Go to point 9 in next table.

## 9. TROUBLESHOOTING (CONT'D)

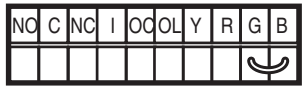
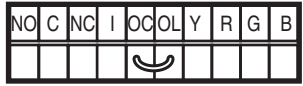
	PROBLEMS	POSSIBLE CAUSES	YOU SHOULD TRY THIS
1	The error code E1 is displayed on Altitude, Platinum or Deco-Touch wall control screen.	<ul style="list-style-type: none"> <li>Unit not compatible with control.</li> <li>The wires may be in reverse position.</li> <li>The wires may be misconnected.</li> <li>The wires may be broken.</li> </ul>	<ul style="list-style-type: none"> <li>Check table on page 2 for control compatibility.</li> <li>Ensure that the color coded wires have been connected to their appropriate places.</li> <li>Ensure the wires are correctly connected.</li> <li>Inspect every wire and replace any that is damaged. If wires are hidden into walls, test the control using a shorter wire.</li> </ul>
2	There is no outside temperature displayed on Altitude or Platinum wall control screen  .	<ul style="list-style-type: none"> <li>The unit is in error.</li> <li>RED wire in control cable damaged or misconnected.</li> </ul>	<p>NOTE: At its very start-up or after a power failure, it takes some minutes before the outside temperature appears on screen. The shortest delay is obtained when the wall control is set on MIN or MAX in VENT Mode.</p> <ul style="list-style-type: none"> <li>Check the unit LED to see if it is flashing; if so, refer to the previous table.</li> <li>Ensure the RED wire is not damaged and properly connected.</li> </ul>
3	Altitude, Platinum or Deco-Touch wall control screen alternates between normal display and E3.	<ul style="list-style-type: none"> <li>The Altitude, Platinum or Deco-Touch wall control may be defective.</li> </ul>	<ul style="list-style-type: none"> <li>Replace the Altitude, Platinum or Deco-Touch wall control.</li> </ul>
4	The wall control does not work.	<p><b>S10 ERV, S10c ERV, 70E and 70Ec units only:</b></p> <ul style="list-style-type: none"> <li>Unit integrated control set to low or high speed (AMBER or GREEN continuous LED).</li> </ul> <p><b>All units:</b></p> <ul style="list-style-type: none"> <li>Unit not compatible with control.</li> <li>The wires may be in reverse position.</li> <li>The wires may be misconnected.</li> <li>The wires may be broken.</li> <li>Defective wall control.</li> </ul>	<ul style="list-style-type: none"> <li>Press on the integrated push button until the LED turns off.</li> <li>Check table on page 2 for control compatibility.</li> <li>Ensure that the color coded wires have been connected to their appropriate places.</li> <li>Ensure the wires are correctly connected.</li> <li>Inspect every wire and replace any that are damaged.</li> <li>Replace the wall control.</li> </ul>
5	Unit does not work (LED not lit on power up).	<ul style="list-style-type: none"> <li>Unit is unplugged.</li> <li>No power to power outlet.</li> <li>The fuse may be defective.</li> <li>J10, J9, or J8 connector(s) may be unplugged.</li> <li>The transformer may be defective (no 9.5 VAC between J8-4 and J8-5).</li> <li>The PCB may be defective.</li> </ul>	<ul style="list-style-type: none"> <li>Make sure the unit is plugged.</li> <li>Test the power outlet with another electrical device (e.g.: a lamp). If it does not work, call an electrician.</li> <li>Check if fuse F1 (located on the PCB) is blown. In that case, replace fuse F1 as per product nameplate.</li> <li>Check the connection of J10, J9, and J8 connector(s).</li> <li>With unit powered and J9 connected, check if there is about 9.5 VAC between transformer connector J8-4 and J8-5 (YELLOW wires). If no, change the transformer.</li> <li>Unplug the unit. Disconnect the main control and the auxiliary control(s) (if need be). Jump <b>G</b> and <b>B</b> terminals.  <small>VE0097</small></li> <li>Plug the unit back and wait about 10 seconds. If the motors run on high speed and the damper opens, the circuit board is not defective.</li> </ul>
6	The Dehumidistat OR other auxiliary control does not work.	<ul style="list-style-type: none"> <li>The wires may be in reverse position.</li> <li>The wires may be misconnected.</li> <li>The wires may be broken.</li> <li>The Dehumidistat or push button may be defective.</li> </ul>	<ul style="list-style-type: none"> <li>Ensure that the color coded wires have been connected to their appropriate places.</li> <li>Ensure the wires are correctly connected.</li> <li>Inspect every wire and replace any that is damaged. If wires are hidden into walls, test the control using a shorter wire.</li> <li>Jump the <b>OL</b> and <b>OC</b> terminals. If the unit switch to high speed, remove the Dehumidistat or push button  <small>VE0098</small> and test it right beside the unit using another shorter wire. If it works here, change the wire. If it doesn't, change the Dehumidistat or the push button.</li> </ul>



## 9. TROUBLESHOOTING (CONT'D)

	PROBLEMS	POSSIBLE CAUSES	YOU SHOULD TRY THIS
7	The damper system does not work (S10 ERVplus, S10n ERVplus, 70E+ and 70EN+ units only) ( <b>AMBER error code</b> ).	<p><b>At power up, no RED LED.</b>  <b>At power up, LED lights RED and there is a clicking sound coming from electrical compartment, but damper does not move:</b></p> <ul style="list-style-type: none"> <li>• Ice or other things hindering the damper movement.</li> <li>• J12 unconnected or bad contact.</li> <li>• Wrong connection of J8.</li> <li>• The transformer may be defective (no 24 VAC between J8-1 and J8-2).</li> </ul> <p>• The damper actuator may be defective.</p> <p><b>Damper moves but does not stop when supposed to:</b></p> <ul style="list-style-type: none"> <li>• Bad connection of J12 connector.</li> <li>• Damper PCB defective or damper motor stripped gear.</li> <li>• The main PCB is defective.</li> </ul>	<ul style="list-style-type: none"> <li>• See point 5.</li> <li>• Remove ice or hindering elements.</li> <li>• Check J12 connection (both harness side and board side).</li> <li>• Check J8 connection.</li> <li>• With unit powered and J9 connected, check if there is about 20-24 VAC between transformer connector J8-1 and J8-2 (ORANGE wires). If no, change the transformer.</li> <li>• Replace the damper system.</li> <li>• Check J12 connection (both harness side and board side).</li> <li>• Replace the damper system.</li> <li>• Replace the main PCB.</li> </ul>
8	<p>A. The supply motor does not work, but exhaust motor works.</p> <p>B. The LED flashes RED.</p>	<ul style="list-style-type: none"> <li>• The supply motor may be defective.</li> <li>• The supply motor capacitor or the PCB may be defective.</li> <li>• The exhaust motor may be defective.</li> <li>• The exhaust motor capacitor may be defective.</li> <li>• Transformer wire(s) bad connection.</li> <li>• The transformer or the PCB may be defective.</li> </ul>	<ul style="list-style-type: none"> <li>• Plug supply motor to J5 connector and exhaust motor to J4 connector. If the LED flashes RED, the supply motor is defective. If exhaust motor works, plug back supply motor to J4 connector and exhaust motor to J5 connector, then check for supply motor capacitor validity.</li> <li>• Plug supply motor capacitor to J7 connector and exhaust motor capacitor to J6 connector. If the LED flashes RED, the supply motor capacitor is defective. If there is no change, the PCB is defective.</li> <li>• Plug exhaust motor to J4 connector and supply motor to J5 connector. If supply motor works but exhaust motor does not, exhaust motor is defective. If exhaust motor works, plug back supply motor to J4 connector and exhaust motor to J5 connector, then check for exhaust motor capacitor validity.</li> <li>• Plug exhaust motor capacitor to J6 connector and exhaust motor capacitor to J7 connector. If exhaust motor works but supply motor does not, the exhaust motor capacitor is defective. If there is no change, check validity of transformer or PCB.</li> <li>• Check J8 and J9 connectors, as well as BLUE and RED wire connections from J9.</li> <li>• Move JU1 jumper from pins 2 and 3 to pins 1 and 2. Set the unit on high speed. If exhaust motor works, the transformer is defective. If it still does not, change the PCB.</li> </ul>
9	Unit shows protection mode error (different than being in protection mode)	<ul style="list-style-type: none"> <li>• Wrong selection of defrost cycle.</li> <li>• Defective motor or damper.</li> <li>• Stale air flow choked (unbalanced unit, filters or outside port clogged, etc.).</li> <li>• Inside temperature too low (around 18°C).</li> </ul>	<ul style="list-style-type: none"> <li>• Refer to Section 3.2 or 3.4, according to the unit model.</li> <li>• Inspect the complete unit, make sure both motors are running, make sure the damper system closes and seal properly.</li> <li>• Inspect the complete ducting, clean the filters, stale air inside grille, etc., balance the unit).</li> <li>• Unit is using the inside temperature to defrost itself, so a very low room temperature can harm the defrost system of the unit.</li> </ul>